

# **Experimental Study of Pulse Tube Refrigerators**

A THESIS SUBMITTED IN PARTIAL FULFILLMENT  
OF THE REQUIREMENTS FOR THE DEGREE OF

**Bachelor of Technology**  
**In**  
**Mechanical Engineering**

**By**  
**V.Venkatesh and R.Chandru**



**Department of Mechanical Engineering**  
**National Institute of Technology**

**Rourkela**

**2007**



**National Institute of Technology  
Rourkela**

## **CERTIFICATE**

This is to certify that the thesis entitled “**Experimental Study of Pulse Tube Refrigerators**” submitted by **V.Venkatesh, Roll No: 10303008** and **R.Chandru, Roll No: 10303014** in the partial fulfillment of the requirement for the degree of **Bachelor of Technology in Mechanical Engineering**, National Institute of Technology, Rourkela, is being carried out under my supervision.

To the best of my knowledge, the matter embodied in the thesis has not been submitted to any other university/institute for the award of any degree or diploma.

Date:

**Professor**

**Dr.R.K.Sahoo**

Department of Mechanical Engineering

National Institute of Technology

Rourkela-769008

## **Acknowledgment**

We avail this opportunity to extend our hearty indebtedness to our guide **Dr. R. K. Sahoo**, Mechanical Engineering Department, for his valuable guidance, constant encouragement and kind help at different stages for the execution of this dissertation work.

We also express our sincere gratitude to **Dr. B. K. Nanda**, Head of the Department, Mechanical Engineering, for providing valuable departmental facilities.

### **Submitted by:**

**V.Venkatesh**  
Roll No: 10303008  
Mechanical Engineering  
National Institute of Technology  
Rourkela

**R.Chandru**  
Roll No: 10303014  
Mechanical Engineering  
National Institute of Technology  
Rourkela

## CONTENTS

<u>Description</u>	<u>Page No:</u>
<b>Abstract</b>	<b>5</b>
<b>1. Introduction</b>	<b>6-10</b>
<b>2. Theory</b> <b>*Design of Pulse Tube Refrigerators</b>	<b>11-14</b>
<b>3. Types of Cryocoolers</b> <b>*Recuperative Coolers</b> <b>*Regenerative Coolers</b> <b>*Pulse Tube Refrigerators</b>	<b>15-19</b>
<b>4. Analysis of Pulse Tube Refrigerators</b> <b>*Enthalpy and Entropy Flow Model</b> <b>*Pulse Tube Losses and Figure of Merit</b> <b>*Effect of Phase between Flow and Pressure</b> <b>*Double Inlet Pulse Tube Refrigerator</b>	<b>20-28</b>
<b>5. Applications</b>	<b>29-30</b>
<b>6. Experimental Study</b>	<b>31-37</b>
<b>7. Result</b>	<b>38</b>
<b>8. Conclusion</b>	<b>38</b>

## **LIST OF FIGURES**

- Fig: 1.1      Basic Pulse Tube Refrigerator**
- Fig: 1.2      Orifice Pulse Tube**
- Fig: 1.3      Multiple By-pass Pulse Tube**
- Fig: 1.4      Parts of a pulse tube**
- Fig: 2.1      Anology between pulse tube and Stirling cycle**
- Fig: 2.2      The Stirling Cycle**
- Fig: 3.1      Model of a Grifford-McMahon Refrigerator**
- Fig: 4.1      Orifice valve structures**
- Fig: 4.2      Double Inlet Pulse Tube Refrigerator**
- Fig: 6.1      Schematic diagram of pulse tube refrigerator**
- Fig: 6.2      Graphical representation**

## **Abstract**

The working fluid for the pulse tube refrigerator is Helium, which is non-toxic to humans and harmless to the environment. The Pulse Tube Refrigeration unit offers a viable alternative to units that currently require CFC and HCFC working fluids.

Pulse Tube Refrigerators can be operated over wide range of temperatures. These units can be used in numerous space and commercial applications, including food freezers freeze dryers. It can also be used to cool detectors and electronic devices.

The design of Pulse Tube Refrigeration Unit was based on Orifice Pulse Tube Concept. First the gas is compressed in a compressor. Next it flows through the compressor after cooler, where heat is rejected to the water cooled loop. Then the gas enters the regenerator and cold end heat exchanger where heat is added to the gas from surroundings.

The gas finally enters the Pulse Tube, orifice and reservoir. These three components produce the phase shift of mass flow and pressure, which is necessary for cooling. The gas shuttles forth between hot and cold ends. Heat is lifted against the temperature gradient and rejected at hot end heat exchanger, which is water cooled.

# **CHAPTER ONE**

## **INTRODUCTION**

## INTRODUCTION

Pulse Tube Coolers are a recent innovation. They were first reported by Prof. W. Gifford and his graduate student, R. Longworth, of Syracuse University. Prof. Gifford had noticed that blanked off plumbing lines connected to gas compressors got hot at the closed end. Connecting such a line to a compressor through a regenerator produced cooling at one end and heating at the other. This was the Basic Pulse Tube. In the first report, 150 Kelvin was achieved in a one stage cooler and 120 Kelvin in a two stage device. A few years later the coolers had reached 120 Kelvin and 85 Kelvin respectively. This performance was not encouraging. The coolers were too inefficient. By the end of the 1960's Pulse Tubes had become an intellectual curiosity and were abandoned as a useful cooler.

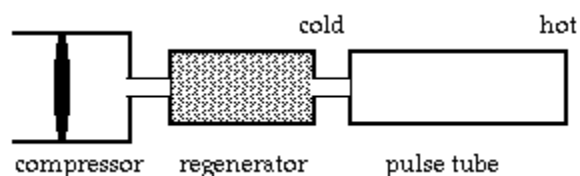

**Fig : 1.1 Basic Pulse Tube Refrigerator**

In the late 1970's, Dr. J. Wheatley at the DOE's Los Alamos National Laboratory became interested in a related technology: thermo-acoustic engines and coolers. These are a class of inherently irreversible machines that operate at acoustic resonance (Pulse Tubes operate at frequencies well below resonance). These devices are even less efficient. The coolers were driven by a simple loudspeaker; while the engines had no moving parts other than the working fluid.

In 1981, after hearing a talk by Dr. Wheatley (16th International Conference on Low Temperature Physics), Dr. P. Kittel of NASA's Ames Research Center recognized the potential for space applications of a cooler with a single moving part. The principal benefits are greater reliability and lower cost compared to the Stirling cooler and an order of magnitude lower mass, lower cost, and longer life than the current state of the art coolers: stored cryogenes. Another benefit is that there are no cold moving parts which enhances life time and removes vibration causing components from the cold head.



Additionally, Pulse Tubes use the same technologies as Stirling coolers. They could benefit from all the flexure-bearing, gas-gap seal compressor and regenerator developments that were just starting for space qualified Stirling coolers.

In 1982, Dr. Kittel in partnership with Dr. R. Radebaugh of NIST began developing Pulse Tubes. The first breakthrough came the next year. At the 1983 Cryogenic Engineering Conference, Dr. E. Mikulin (Moscow Bauman State Technical University, Russia, formerly the Moscow High Technical School, USSR) showed that the efficiency could be increased by inserting an orifice and reservoir at the hot end. This increased the phase shift between the pressure and mass flow oscillations. This observation led to the Orifice Pulse Tube which has become the standard implementation. Single stage Orifice Pulse Tubes have reached temperatures below 30 Kelvin (various workers, late 1980's); while a 3-stage device built by Prof. Matsubara at Nihon University in Japan has reached 3.6 Kelvin (15th International Cryogenic Engineering Conference, 1994).

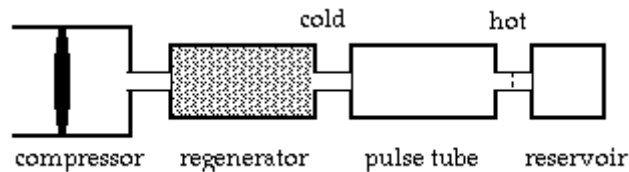
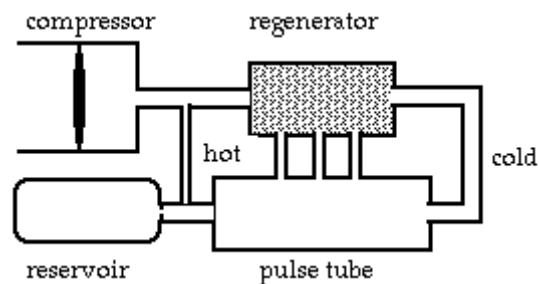

**Fig: 1.2 Orifice Pulse Tube**

By the late 1980's, a good theoretical understanding had been developed at NIST (NASA funded). This was 1-D thermodynamic model based on Enthalpy flow. During this time, technology transfer from the NIST/NASA team was well under way with a number of companies. The biggest industrial effort was at TRW. They started in 1987 with a development contract from NASA Ames and with substantial in-house funding. TRW built a number of Pulse Tubes, including the first one to operate below 10 Kelvin. In 1994 TRW delivered its first Pulse Tube built under contract to the Air Force's Phillips Laboratory. The success of this cooler (1 watt at 35 Kelvin with 200 watts of input power) led to TRW being selected to build a Pulse Tube for the AIRS instrument for the EOS program. This is a 1.5 watts at 55 Kelvin cooler with an input power of less than 100 watts; an efficiency comparable to Stirling coolers.

Meanwhile; Dr. G. Swift at Los Alamos with DoE funds had continued developing the thermo-acoustic compressor. The compressor was coupled to a Pulse Tube developed by Dr. R. Radebaugh at NIST. This produced a cooler with no moving parts (4th Interagency Meeting on Cryocoolers, 1990). The cooler reached 90 Kelvin and produced 5 watts of cooling at 120 Kelvin with an input thermal power of 3 kilowatts. Not very efficient, but tremendous potential for reliability!

By the late 1980's many laboratories around the world had started Pulse Tube development. The principal groups are located in China, Japan, France and Germany. Many different configurations have been investigated. One of the most active is the group lead by Prof. Matsubara (Nihon University, Japan). They were the first to develop the moving plug or hot piston Pulse Tube. This added a second moving component and increases the efficiency. The most important development has been the innovation of the double inlet Pulse Tube by Dr. Zh of Xi'an Jiaotong University, China (13th International Cryogenic Engineering Conference, 1990). This technique was further refined into the multiple by-pass Pulse Tube by Dr. Zhou of the Academia Sinica, China (7th International Cryocooler Conference, 1992). In 1994, the first commercially available Pulse Tube was announced in Japan by Iwatani as a replacement for the cold head of a Gifford-McMahon cooler. (Gifford-McMahon coolers are a low cost variation of a Stirling cooler. They are the most common type of cryogenic refrigerator sold industrially.)



**Fig: 1.3 Multiple By-pass Pulse Tube**

The quality of the analytic models has also improved over the years. NASA Ames has been developing a 2-D model that incorporates both thermodynamics and hydrodynamics. This model has shown that there are secondary flows in the system that

earlier 1-D models had ignored. The existence of these secondary flows has been confirmed by flow measurements made at NASA Ames (8th International Cryocooler Conference, 1994). Current work at Ames also includes the fabrication of a 4-stage Pulse Tube based on the multiple by-pass approach.

A number of American manufactures are also interested in replacing Gifford-McMahon coolers with Pulse Tubes; although, none of the major industrial manufactures are close to making this change. When they make this change, the new coolers will be lower cost, lower vibration, and more reliable. Most of the non-aerospace work on Pulse Tubes has been in small companies working with SBIR contracts ([click here for information on NASA's SBIR program](#)).



**Fig: 1.4 Parts of a pulse tube**

# **CHAPTER TWO**

## **THEORY**

### **THEORY**

The theory behind Pulse Tube Coolers is very similar to that of the Stirling Refrigerators, with the volume displacement mechanism of the displacer replaced by the orifice / surge volume configuration.

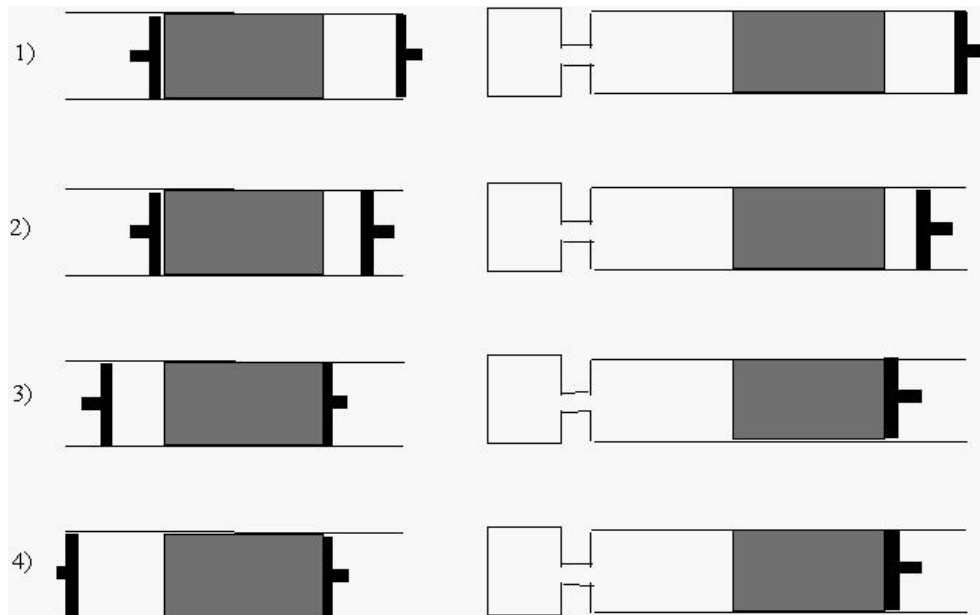

**Fig: 2.1 Analogy between pulse tube and Stirling cycle**

Figure 1 shows the analog between the Stirling cooler and the pulse tube. As the compressor piston compresses from 1) to 2), the pressure in the system increases. During this phase, very little gas is transferred into the surge volume via the orifice, as the initial pressure difference across the orifice is small. As the piston compresses further from 2) to 3), more working gas passes through the orifice into the surge volume. The end result is very close to an isochoric process in a Stirling cycle (with the expansion of the displacer). The net effect is that the working gas is displaced across regenerator with heat transfer between the gas and the matrix material. As the compressor piston reaches its maximum stroke and becomes stationary 3) to 4), expansion occurs because gas continues to flow into the surge volume, which is at a lower pressure and the pressure within the pulse tube system drops. Finally, a combination of gas exiting the surge volume and the expansion of the compression space result in another near-isochoric process, 4) to 1) that completes

the cycle. As a result, an amount of heat,  $Q_H = T_H dS$  is rejected from the system while  $Q_C = T_C dS$  is absorbed at the cold tip (Fig 2).

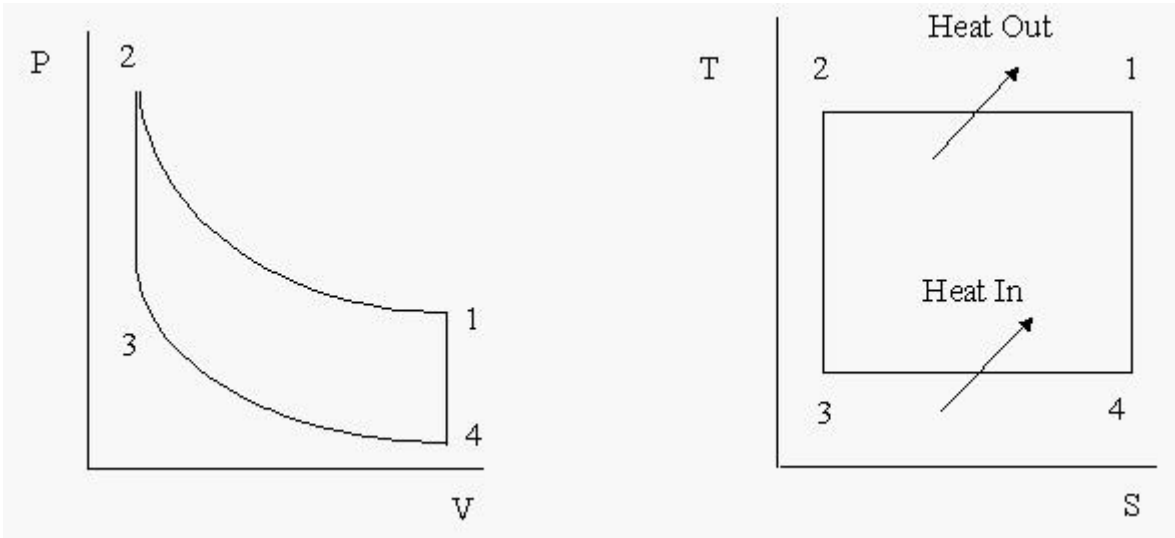

**Fig : 2.1 The Stirling Cycle.**

## **DESIGN OF PULSE TUBE REFRIGERATORS**

The Pulse Tube Refrigeration unit is based on the Orifice Pulse Tube Concept. The gas is compressed in the compressor. The compressor designed and built for this unit is a dual-opposed piston type. The displacement of these two pistons is 180 degrees out of phase to reduce vibrations. It is designed for operation at a normal 60 Hz. Then the compressor gas flows through the compressor after cooler, where heat is rejected to the water-cooling loop. This gas flows through the regenerator, which is basically an economizer, conserving cooling from one cycle to the next. The gas then enters the cold end heat exchanger, where heat is added to the gas from surroundings. This gas finally enters the pulse tube, orifice and reservoir. These three components produce the phase shift of the mass flow and pressure, which is necessary for cooling. The gas shuttles forth between the hot and cold ends rather than circulating around a loop, as in some refrigeration cycles. Heat is lifted against the temperature gradient and rejected at the hot end heat exchanger, which is water-cooled.

The compressor pistons are supported by helical-mechanical springs which assist in producing harmonic motion and return the pistons to the needed null positions before startup. The pistons are supported inside the cylinder on dry, lubricated, low friction bearings. Each piston is attached by a separate moving coil, which is formed by wrapping copper wire around the end of spool. When voltage is applied to the coil, the resulting produces a force on the coil.

The cold end and hot end heat exchangers consist of fine copper mesh screens, fabricated using proprietary techniques.

After design and fabrication, the pulse tube refrigeration unit was subjected to numerous tests. Pulse tube refrigerators offer increased reliability, fewer moving parts and much lower cold end vibration than the other spacecraft or commercial refrigeration concepts.

## **CHAPTER THREE**

### **TYPES OF CRYOCOOLERS**

- (a) Recuperative Coolers**
- (b) Regenerative Coolers**
- (c) Pulse Tube Refrigerators**

### **TYPES OF CRYOCOOLERS**



## RECUPERATIVE COOLERS

Cryocoolers can be classified as either recuperative or regenerative. The recuperative coolers use only recuperative heat exchangers and operate with a steady flow of refrigerant through the system. The compressor operates with a fixed inlet pressure and a fixed outlet pressure. If the compressor is a reciprocating type, it must have inlet and outlet valves (valved compressor) to provide the steady flow. Scroll, screw or centrifugal compressors do not need valves to provide the steady flow. Figure 1 shows schematics of the most common recuperative cryocooler cycles. The Joule-Thomson (JT) cryocooler is very much like the vapor-compression refrigerator, except that the main heat exchanger is almost nonexistent in the vapor-compression refrigerator because the temperature span is so low. In vapor-compression refrigerators the compression takes place below the critical temperature of the refrigerant. As a result, liquefaction at room temperature occurs in the aftercooler. Expansion of the liquid in the JT little or no heat exchange with the returning cold, expanded gas is required. Most early Joule-Thomson refrigerators used a pure fluid, such as nitrogen, to reach a temperature of about 77 K, the normal boiling point for nitrogen. The compression process at room temperature takes place at a temperature much above the 126 K critical temperature of high as 20 MPa is only about 25 K. Thus, a very efficient recuperative heat exchanger is required to reach cryogenic temperatures. More recently the pure fluids have been replaced with mixed gases, such as nitrogen, methane, ethane, and propane in the JT refrigerators to improve their performance and reduce the required pressure on the high side [3, 7, 8]. Nevertheless, the with an expansion engine or turbine. Thus, the Brayton cryocooler, shown in Fig. 1b offers the potential for higher efficiency with a sacrifice in simplicity, cost, and possibly reliability. The Claude cycle combines the JT and the Brayton cycles. It is used primarily for gas liquefaction where liquid may damage the expansion engines or turbines. The use of valves in compressors or the high pressure-ratios needed for recuperative cryocoolers limits the efficiency of the compression process to about 50% and significantly limits the overall efficiency of recuperative refrigerators.

High reliability in vapor-compression refrigerators is achieved partly because of the use of oil lubricated compressors. Oil entrained in the refrigerant can be circulated through the cold part of the system since it does not freeze at these temperatures. However, it would freeze at cryogenic temperatures, which then necessitates that all oil be removed from the refrigerant in cryocoolers or that oil-free compressors be used. Long lifetimes are then much more difficult to achieve in cryogenic systems.

## **REGENERATIVE CRYOCOOLERS**

The regenerative cryocoolers, as shown in Fig. 2, use at least one regenerative heat exchanger, or regenerator, and operate with oscillating flow and pressure. They are analogous to AC electrical systems, whereas the recuperative cryocoolers are analogous to DC electrical systems. In such an analogy pressure is analogous to voltage, and mass flow or volume flow is analogous to current. Further comparisons with electrical systems will be discussed later. In a regenerator incoming hot gas transfers heat to the matrix of the regenerator, where the heat is stored for a half cycle in the heat capacity of the matrix. In the second half of the cycle the returning cold gas, flowing in the opposite direction through the same channel, picks up heat from the matrix and returns the matrix to its original temperature before the cycle is repeated. At equilibrium one end of the regenerator is at room temperature while the other end is at the cold regenerators through the use of stacked fine-mesh screen or packed spheres.

## **PULSE TUBE REFRIGERATORS**

The moving displacer in the Sterling and Gifford-McMahon refrigerators has several disadvantages. It is a source of vibration, has a short lifetime, and contributes to axial heat conduction as well as to a shuttle heat loss. In the pulse tube refrigerator, the displacer is eliminated. The proper gas motion in phase with the pressure is achieved by the volume is large enough that negligible pressure oscillation occurs in it during the oscillating flow. The oscillating flow through the orifice separates the heating and cooling effects just as the displacer does for the Stirling and Gifford-McMahon

refrigerators. The orifice pulse tube refrigerator (OPTR) operates ideally with adiabatic compression and expansion in the pulse tube. Because this heated, compressed gas is at a higher pressure than the average in the reservoir, it flows through the orifice into the reservoir and exchanges heat with the ambient through the heat exchanger at the warm end of the pulse tube. The flow stops when the pressure in the pulse tube is reduced to the average pressure. (3) The piston moves up and expands the gas adiabatically in the pulse tube. (4) This cold, low-pressure gas in the pulse tube is forced toward the cold end by the gas flow from the reservoir into the pulse tube through the orifice. As the cold gas flows through the heat exchanger at the cold end of the pulse tube it picks up heat from the object being cooled. The flow stops when the pressure in the pulse tube increases to the average pressure. The cycle then repeats. The function of the regenerator is the same as in the Stirling and Gifford-McMahon refrigerators in that it pre-cools the incoming high pressure gas before it reaches the cold end. The function of the pulse tube is to insulate the processes at its two ends. That is, it must be large enough that gas flowing from the warm end traverses only part way through the pulse tube before flow is reversed. Likewise, flow in from the cold end never reaches the warm end. Gas in the middle portion of the pulse tube never leaves the pulse tube and forms a temperature gradient that insulates the two ends. Roughly speaking, the gas in the pulse tube is divided into three segments, with the middle segment acting like a displacer but consisting of gas rather than a solid material. For this gas plug to effectively insulate the two ends of the pulse tube, turbulence in the pulse tube must be minimized. Thus, flow straightening at the two ends is crucial to the successful operation of the pulse tube refrigerator. The pulse tube is the unique component in this refrigerator that appears not to have been used previously in any other system. It could not be any simpler from a mechanical standpoint. It is simply an open tube. But the thermohydrodynamics of the processes involved in it are extremely complex and still not well understood or modeled. Its function is to transmit hydrodynamic power in an oscillating gas system from one end to the other across a temperature gradient with a minimum of power dissipation and entropy generation. As shown in Figure 2b the compressor for the pulse tube refrigerator is a valveless type, sometimes referred to as a Stirling-type compressor. As mentioned previously, this is actually a pressure oscillator. The pulse tube refrigerator can be driven

with any source of oscillating pressure. It can be, and often is, driven with a valved compressor like that for the Gifford- McMahon refrigerator. Other sources of pressure oscillation will be discussed later.

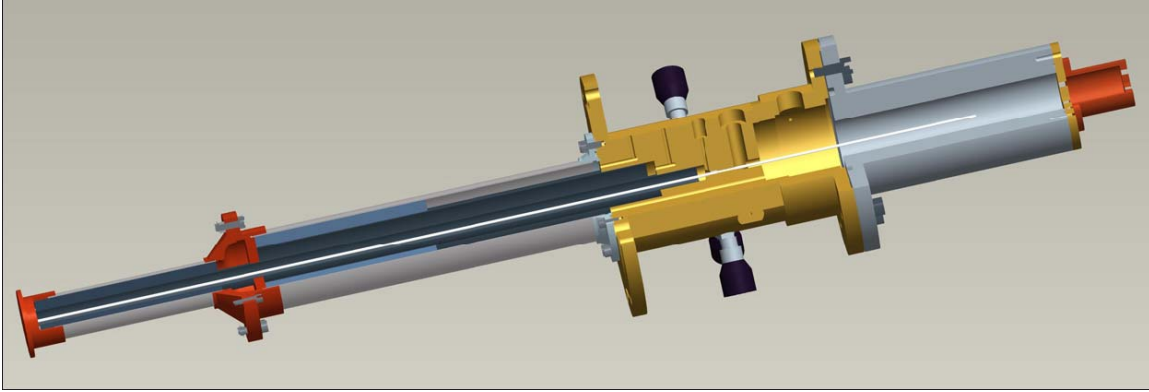

**Fig : 3.1 Model of a Grifford-McMahon Refrigerator**

## **CHAPTER FOUR**

### **ANALYSIS OF PULSE TUBE REFRIGERATORS**

- (a) Enthalpy and Entropy Flow Model**
- (b) Pulse Tube Losses and Figure of Merit**
- (c) Effect of Phase between Flow and Pressure**
- (d) Double Inlet Pulse Tube Refrigerator**

## ANALYSIS OF PULSE TUBE REFRIGERATORS

### ENTHALPY AND ENTROPY FLOW MODEL

The refrigeration power of the OPTR is derived using the First and Second Laws of Thermodynamics for an open system. Because of the oscillating flow the expressions are simplified if averages over one cycle are made. Even though the time-averaged mass flow rate is zero, other time-averaged quantities, such as enthalpy flow, entropy flow, etc., will have nonzero values in general. We define positive flow to be in the direction from the compressor to the orifice. The First Law balance for the cold section is shown in Figure 3. No work is extracted from the cold end, so the heat absorbed under steady state conditions at the cold end is given by

$$Q_c = H - H_r \quad \rightarrow (1)$$

Where

$H$  is the time-averaged enthalpy flow in the pulse tube,

$H_r$  is the time-averaged enthalpy flow in the regenerator, which is zero for a perfect regenerator and an ideal gas.

The maximum, or gross, refrigeration power is simply the enthalpy flow in the pulse tube, with the enthalpy flow in the regenerator being considered a loss. Combining the First and Second Laws for a steady-state oscillating system gives the time-averaged enthalpy flow at any location as

$$H = P_d V + T_0 S \quad \rightarrow (2)$$

Where

$P_d$  is the dynamic pressure,  $V$  is the volume flow rate

$T_0$  is the average temperature of the gas at the location of interest

$S$  is the time-averaged entropy flow.

The first term on the right hand side of Eq. (2) represents the potential of the gas to do reversible work in reference to the average pressure  $P_0$  if an isothermal expansion process

occurred at  $T_0$  in the gas at that location. Since it is not an actual thermodynamic work term, it is sometimes referred to as the hydrodynamic work flow, hydrodynamic power, or acoustic power. Equation (2) shows that the acoustic power can be expressed as an availability or energy flow with the reference state being  $P_0$  and  $T_0$ . The specific availability or energy is given as  $h - T_0s$ . Processes within the pulse tube in the ideal case are adiabatic and reversible. In this case entropy remains constant throughout the cycle, which gives

$$\mathbf{S = 0 (ideal case). \quad \rightarrow(3)}$$

Equations (1) and (2) are very general and apply to any oscillating thermodynamic system, even if the flow and pressure are not sinusoidal functions of time. If they are sinusoidal, the acoustic power can be written as

$$\begin{aligned} P_d V &= 0.5 * P_1 V_1 \text{Cos}\theta \\ &= 0.5 * RT_0 m_1 * (P_1/P_0) \quad \rightarrow(4) \end{aligned}$$

Where

$P_1$  is the amplitude of the sinusoidal pressure oscillation

$V_1$  is the amplitude of the sinusoidal volume flow rate

$\theta$  is the phase angle between the flow and the pressure

$R$  is the gas constant per unit mass

$M_1$  is the amplitude of the sinusoidal mass flow rate.

Equations (1-3) can be combined to give the maximum or gross refrigeration power in terms of acoustic power as

$$\mathbf{Q_{max} = P_d V \quad \rightarrow(5)}$$

This simple expression is a very general expression and applies to the Stirling and Gifford- McMahon refrigerators as well. In those two refrigerators the acoustic work is converted to actual expansion work by the moving displacer. That work is easily measured by finding the area of the PV diagram. In the case of the pulse tube refrigerator there is no moving displacer to extract the work or to measure a PV diagram. Thus, the volume or mass flow rate must be measured by some flow meter to determine the

acoustic power. Such measurements are difficult to perform inside the pulse tube without disturbing the flow and, hence, the refrigeration power. Because there is no heat exchange to the outside along a well-insulated pulse tube, the First Law shows that the time-averaged enthalpy flow through the pulse tube is constant from one end to the other. Then, according to Eq. (2) the acoustic power remains constant as long as there are no losses along the pulse tube to generate entropy. The instantaneous flow rate through the orifice is easily determined by measuring the small pressure oscillation in the reservoir and using the ideal-gas law to find the instantaneous mass flow rate. The instantaneous pressure is easily measured in the warm end of the pulse tube, and the product of it and the volume flow is integrated according to Eq. (5) to find the acoustic power. The enthalpy flow model pertaining to the ideal OPTR and leading to Eqs. (4) and (5) was discussed as early as 1986 by Radebaugh and refined over the next few years.

## **PULSE TUBE LOSSES AND FIGURE OF MERIT**

In an actual pulse tube refrigerator there will be losses in both the regenerator and in the pulse tube. These losses can be subtracted from the gross refrigeration power to find the net refrigeration power. The regenerator loss caused by  $H_r$  is usually the largest loss, and it can be calculated accurately only by complex numerical analysis programs, such as REGEN3.1 developed by NIST. The other significant loss is that associated with generation of entropy inside the pulse tube from such effects as (a) instantaneous heat transfer between the gas and the tube wall, (b) mixing of the hot and cold gas segments because of turbulence, (c) acoustic streaming or circulation of the gas within the pulse tube brought about by the oscillating pressure and gas interactions with the wall, and (d) end-effect losses associated with a transition from an adiabatic volume to an isothermal volume. The time-averaged entropy flows associated with (b), (c), and (d) are always negative, that is, flow from pulse tube to compressor. The entropy flow associated with (a) is negative at cryogenic temperatures, where the critical temperature gradient has been exceeded, but is positive at higher temperatures, where the temperature gradient is less than the critical value. Thermo acoustic models of pulse tube refrigerators, developed between 1988 and 1995, calculate the entropy flow associated with (a), but no models



have been sufficiently developed yet to calculate the entropy flows associated with (b) and (c). Because these entropy flows in the pulse tube are negative, the enthalpy flow, and, hence, the refrigeration power will be less than the acoustic power according to Eq. (2). For an ideal gas the pulse tube figure of merit is defined as:

$$\mathbf{FOM=H/P_dV \quad \rightarrow(6)}$$

Measured values for *FOM* range from about 0.55 to 0.85 in small pulse tubes to as high as 0.96 in very large pulse tubes where acoustic streaming was eliminated with a light taper. These values of *FOM* are then used as empirical factors in calculations of pulse tube performance.

### **EFFECT OF PHASE BETWEEN FLOW AND PRESSURE**

Equation (4) shows that for a given pressure amplitude and acoustic power, the mass flow amplitude is minimized for  $\theta = 0$ . Such a phase occurs at the orifice, that is, the flow is in phase with the pressure. However, because of the volume associated with the pulse tube, the flow at the cold end of the pulse tube then leads the pressure by approximately  $30^\circ$  in a correctly sized pulse tube. The gas volume in the regenerator will cause the flow at the warm end of the regenerator to lead the pressure even further, for example, by  $50$  to  $60^\circ$ . With this large phase difference the amplitude of mass flow at the warm end of the regenerator must be quite large to transmit a given acoustic power through the regenerator. This large amplitude of mass flow leads to large pressure drops as well as to poor heat exchange in the regenerator. These losses are minimized when the amplitude averaged throughout the regenerator is minimized. This occurs when the flow at the cold end lags the pressure and flow at the warm end leads the pressure. A  $30^\circ$  lag at the cold end is the approximate optimum. To achieve this phase angle requires that the flow at the warm end of the pulse tube be shifted away from its normal  $0^\circ$  phase angle to about  $-50$  to  $-60^\circ$ . In the last few years two different mechanisms have been developed to cause a beneficial phase shift between the flow and the pressure at the warm end of the pulse tube. These mechanisms, described in the following section, have led to improved efficiencies in pulse tube refrigerators.

## **DOUBLE INLET PULSE TUBE REFRIGERATOR**

In 1990 Zhu, Wu, and Chen [27] introduced the concept of a secondary orifice to the OPTR in which the secondary orifice allows a small fraction (about 10%) of the gas to travel directly between the compressor and the warm end of the pulse tube, thereby bypassing the regenerator. They called this the double-inlet pulse tube refrigerator. This bypass flow is used to compress and expand the portion of the gas in the warm end of the pulse tube that always remains at the warm temperature. The bypass flow reduces the flow through the regenerator, thereby reducing the regenerator loss. The flow through the secondary orifice is in phase with the pressure drop across the regenerator, which, in turn, is approximately in phase with the flow through the regenerator, averaged over its length. Since the flow usually leads the pressure, so too will the flow through the secondary. This secondary flow then forces the flow at the warm end of the pulse tube to lag the pressure, since the sum of the flows must be in phase with the pressure at the primary orifice. The location of the secondary orifice is shown in Figure 4, along with that of an inertance tube described in the next section.

The double-inlet pulse tube refrigerator led to increased efficiencies, particularly at high frequencies where the regenerator losses would be quite high in a simple OPTR. The secondary orifice was incorporated in the mini pulse tube described by Chan. This refrigerator produced 0.5 W of cooling at 80 K with only 17 W of input power. About 30 of these mini pulse tube refrigerators have been built and are scheduled for a variety of space missions. The secondary orifice has been used on a majority of pulse tube refrigerators built since about 1991.

## **DC FLOW OR STREAMING**

Though the introduction of the secondary orifice usually led to increased efficiencies compared to the OPTR, it also introduced a problem. Performance of the double inlet pulse tube refrigerator was not always reproducible, and sometimes the cold end temperature would slowly oscillate by several degrees with periods of several minutes or more. Researchers were attributing this erratic behavior to DC flow that can occur around

the loop formed by the regenerator, pulse tube, and secondary orifice. Asymmetric flow impedance in the secondary can cause such a DC flow. DC flow carries a large enthalpy flow from the warm to the cold end even for a few percent of the AC amplitude. In 1997 Gideon showed that the acoustic power flowing from the warm to the cold end of the regenerator brings about an intrinsic driving force for DC flow or streaming in the same direction as the acoustic power flow. As a result, an asymmetric secondary is required to cancel the intrinsic tendency for this DC flow. In the author's lab the use of a needle valve for the secondary with the needle pointing toward the warm end of the pulse tube resulted in a no-load temperature on a small pulse tube refrigerator of about 35 K. When the needle valve was reversed, the no-load temperature increased to about 50 K. A tapered tube, also known as a jet pump, has also been used to cancel the DC flow. Direct measurements of this small DC flow superimposed on the AC flow would be nearly impossible and have never been attempted. Instead, it is customary to measure the temperature profile on the outside of the regenerator and compare that with the calculated profile or the measured profile when the secondary is closed. Except for very low temperatures the normalized temperature at the midpoint on the regenerator is about 50 to 55% of the total temperature difference. DC flow from the warm end of the regenerator increases in the midpoint temperature, whereas flow in the opposite direction reduces the midpoint temperature.

## **ACOUSTIC STREAMING**

Another intrinsic streaming effect occurs within a large tube or any structure where the hydraulic radius is significantly larger than the viscous penetration depth. This is known as acoustic streaming and is driven by the oscillating flow and pressure in the viscous boundary layer. In a straight pulse tube this acoustic streaming results in the boundary layer flowing slowly from the cold to the warm end. Conservation of mass flow then requires that a flow in the opposite direction occur near the center of the pulse tube. The flow changes directions at the two ends of the pulse tube. This streaming carries with it a large enthalpy flow from the warm to the cold end of the pulse tube and reduces the figure of merit of the pulse tube as discussed earlier. This acoustic streaming can be

eliminated either with the proper phase angle between flow and pressure or by the use of a tapered pulse tube [26]. So far tapered pulse tubes have been successfully used only in rather large pulse tubes, but much further work is needed, especially in smaller systems.

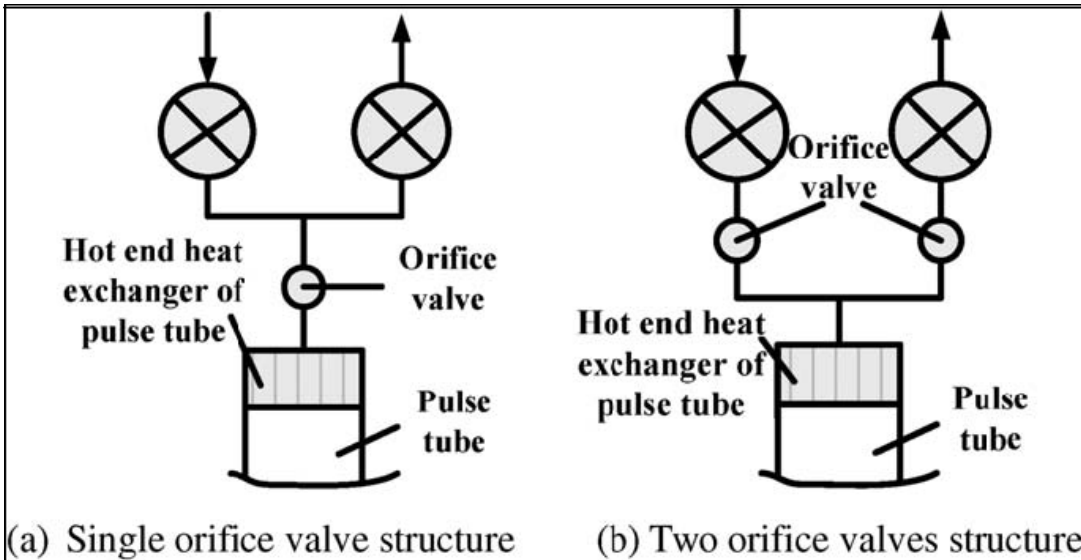
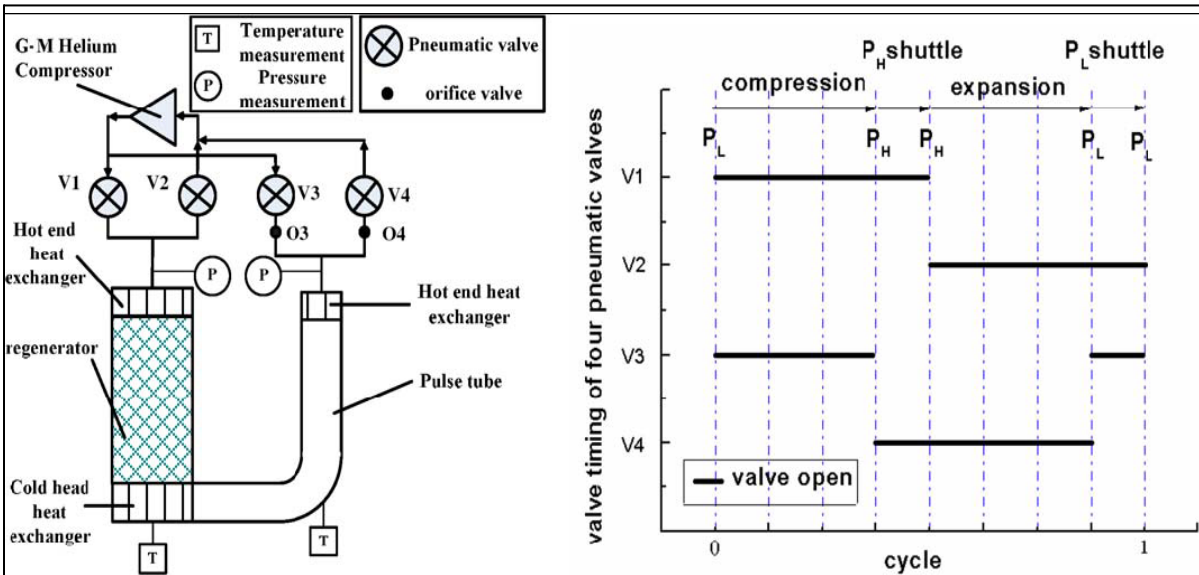
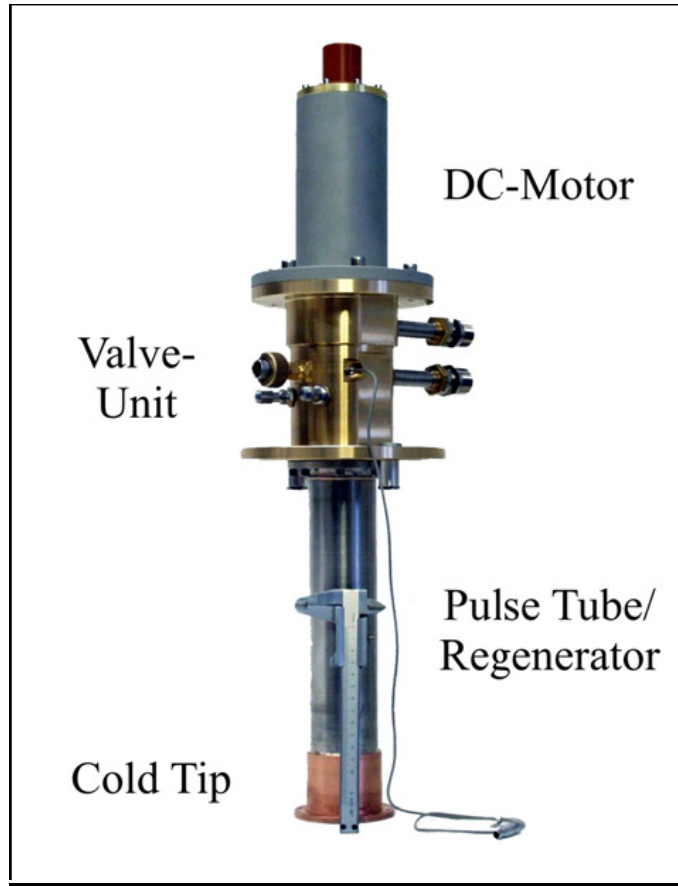

Fig: 4.1 Orifice valve structures





**Fig: 4.2 Double Inlet Pulse Tube Refrigerator**

## **CHAPTER FIVE**

### **APPLICATIONS OF PULSE TUBE**

#### **REFRIGERATORS**

- (a) Military**
- (b) Environmental**
- (c) Commercial**
- (d) Medical**

## **APPLICATIONS OF PULSE TUBE REFRIGERATORS**

### **MILITARY**

- (a) Infra red sensors for missile guidance
- (b) Infra red sensors for satellite surveillance

### **ENVIRONMENTAL**

- (a) Infra red sensors for atmospheric studies of ozone hole and greenhouse effects
- (b) Infra red sensors for pollution monitoring

### **COMMERCIAL**

- (a) High temperature super-conductors for mobile phone base stations
- (b) Semi-conductors for high speed computers
- (c) Super-conductors for voltage standards

### **MEDICAL**

- (a) Cooling of super-conductors for magnets for MRI scans
- (b) SQUID magnetometers for heart and brain study

## **CHAPTER SIX**

### **EXPERIMENTAL STUDY OF PULSE TUBE REFRIGERATORS**



## **EXPERIMENTAL STUDY OF PULSE TUBE REFRIGERATOR**

- (1) Before conducting the experiment, the pulse tube, reservoir, valves and regenerator were checked for leaks.
- (2) The pulse tube refrigerator was then assembled and the setup was done.
- (3) The compressor was turned on and then the pulse tube. The setup was allowed to run for about 3-4 hours so as to achieve steady-state.
- (4) Once steady-state has been achieved, the readings are taken at 5 or 10 minute intervals.
- (5) The temperature at the cold end of the pulse tube and the inlet and outlet pressures of the compressor are measured and noted.

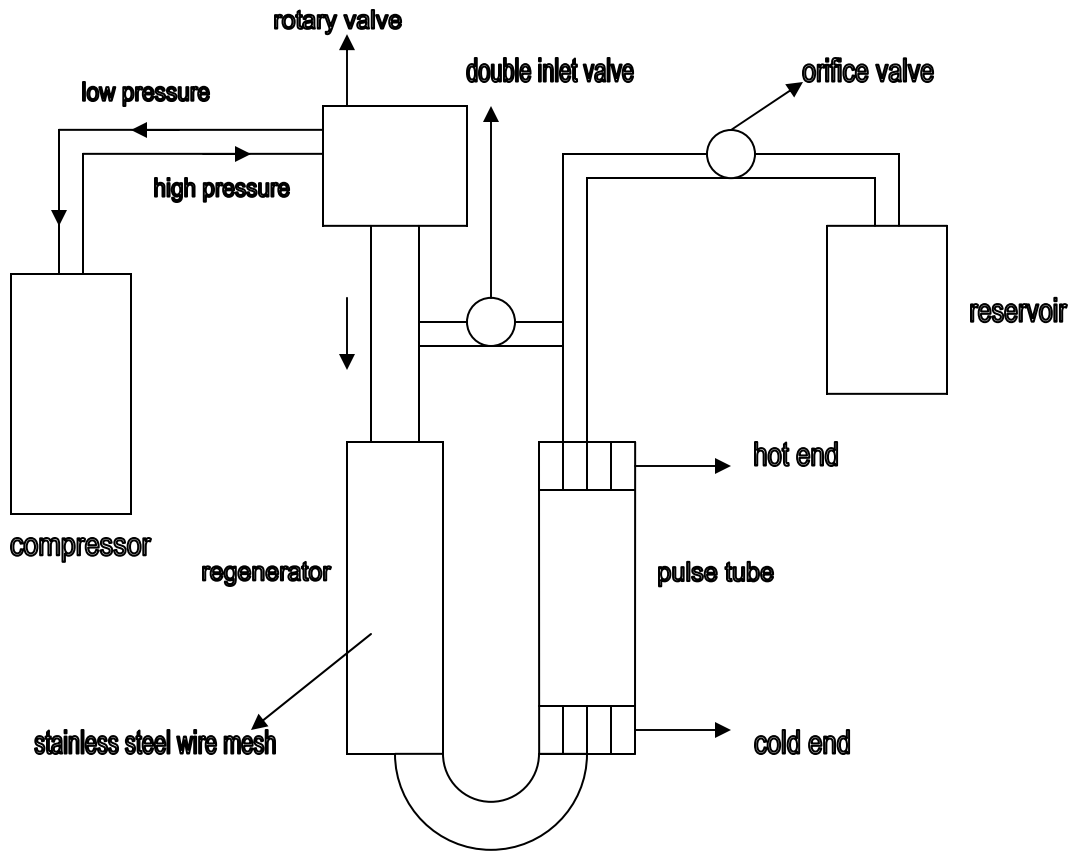
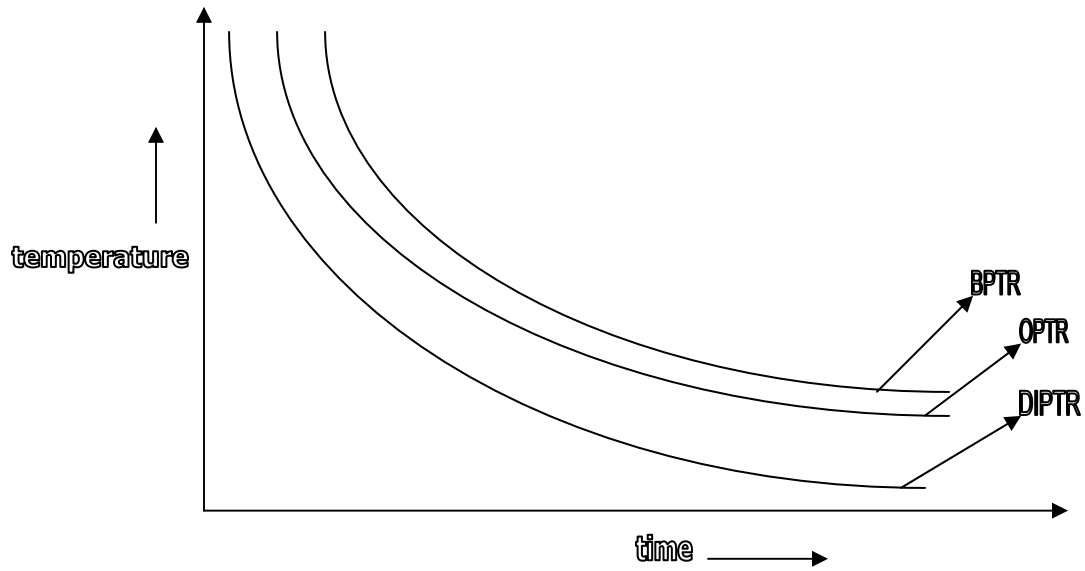

**Fig: 6.1 Schematic diagram of pulse tube refrigerator**

**Tabular Column:**

Time	Temperature(°C)	High pressure(bar)	Low pressure (bar)
9.45	34.9	17	8.5
10.00	17.25	17	8.5
10.05	9.29	16.5	8
10.10	8.01	16.5	8
10.47	8.58	17	7.5
10.52	7.65	16.5	8
10.54	7.20	16	8
10.56	6.56	16	8
10.58	6.12	16.5	8
11.00	5.72	16.5	8
11.10	5.58	16.5	8
11.12	5.44	16.5	8
11.14	5.30	16.5	8
11.16	5.16	16.5	8
11.18	4.94	16.5	8
11.20	4.47	16.5	8
11.22	3.86	16.5	8
11.24	3.48	16.5	8
11.26	3.06	16.5	8
11.28	2.96	16.5	8
11.30	2.22	16.5	8
11.32	2.02	16.5	8
11.34	1.80	16.5	8
11.36	1.58	16.5	8

11.38	1.50	16.5	8
11.40	1.19	16.5	8
11.42	0.33	16.5	8
11.44	0.26	16.5	8
11.46	-0.19	16.5	8
11.48	-0.26	16.5	8
11.50	-0.43	16.5	8
11.52	-0.50	16.5	8
11.54	-0.62	16.5	8
11.56	-0.73	16.5	8
11.58	-0.77	16.5	8
12.00	-0.58	16.5	8
12.02	-0.49	16.5	8
12.04	-0.41	16.5	8
12.06	-0.35	16.5	8
12.08	-1.17	16.5	8
12.10	-2.38	16.5	8
12.12	-3.28	16.5	8
12.14	-4.96	16.5	8
12.15	-5.64	16.5	8
12.18	-6.75	16.5	8
12.20	-7.98	16.5	8
12.25	-8.75	16.5	8
12.30	-9.51	16.5	8
12.32	-10.37	16.5	8



**Fig: 6.2 Graphical representation**

- BPTR** - Basic Pulse Tube Refrigeration [both valve closed]
- OPTR** - Orifice Pulse Tube Refrigeration [orifice opened / double inlet closed]
- DIPTR** - Double Inlet Pulse Tube Refrigeration [both valve opened]

**RESULT:**

A value  $-10.37\text{ }^{\circ}\text{C}$  has been obtained after about two and half an hour of continuous measurement of time, temperature. Values have been noted down at every two, five and ten minutes time interval.

**CONCLUSION:**

A graph has been drawn between time and temperature along x and y-axis respectively. Three curves are obtained. The uppermost curve represents the BPTR [basic pulse tube refrigerator], while the lowermost curve represents the DIPTR [double inlet pulse tube refrigerator], and the intermediate curve indicates the OPTR [orifice pulse tube refrigerator]. This signifies that, when both the valves are kept open [DIPTR], the temperature keeps on decreasing drastically and thereby helps in getting the (required) lowest temperature necessary for cooling the devices, easily. But in the other two cases, the temperature decreases slowly [OPTR, BPTR].

## **REFERENCE:**

- ◆ Cryogenics.nist.gov/papers/institute of refrigeration.
- ◆ [http://ranier.hq.nasa.gov/censors\\_page/cryo/cryopt](http://ranier.hq.nasa.gov/censors_page/cryo/cryopt).
- ◆ [Uspatent6983610.html](http://uspatent6983610.html)
- ◆ [http://www.sciencedirect.com/science?\\_ob=ArticleListURL&\\_method=list&\\_ArticleListID=571041739&\\_sort=d&view=c&\\_acct=C000053917&\\_version=1&\\_urlVersion=0&\\_userid=1657113&md5=e7a594cbb5a7e55cc149c5222a85f19a](http://www.sciencedirect.com/science?_ob=ArticleListURL&_method=list&_ArticleListID=571041739&_sort=d&view=c&_acct=C000053917&_version=1&_urlVersion=0&_userid=1657113&md5=e7a594cbb5a7e55cc149c5222a85f19a)
- ◆ <http://adsabs.harvard.edu/abs/2002AIPC..613..847G>
- ◆ [http://www.sciencedirect.com/science?\\_ob=ArticleURL&\\_udi=B6TWR-4J3WGHF-2&\\_user=1657113&\\_coverDate=05%2F31%2F2006&\\_rdoc=1&\\_fmt=&\\_orig=search&\\_sort=d&view=c&\\_acct=C000053917&\\_version=1&\\_urlVersion=0&\\_userid=1657113&md5=2d134ab281687b7b8a1683c330f8584d](http://www.sciencedirect.com/science?_ob=ArticleURL&_udi=B6TWR-4J3WGHF-2&_user=1657113&_coverDate=05%2F31%2F2006&_rdoc=1&_fmt=&_orig=search&_sort=d&view=c&_acct=C000053917&_version=1&_urlVersion=0&_userid=1657113&md5=2d134ab281687b7b8a1683c330f8584d)
- ◆ <http://adsabs.harvard.edu/abs/2004AIPC..710.1474K>







