

**THERMODYNAMIC, ECONOMIC ANALYSIS
AND DESIGNING OF HEATING SYSTEM FOR THE
SWIMMING POOL PRESENT AT NIT ROURKELA**

A THESIS SUBMITTED IN PARTIAL FULFILMENT OF
THE REQUIREMENTS FOR THE DEGREE OF

Bachelor in Technology

In

Chemical Engineering

Under the guidance of

Prof. SK. Agarwal

By

Priyanka Tiwari

107 CH 034



Department of Chemical Engineering
National Institute of Technology, Rourkela
2007-2011



National Institute of Technology
Rourkela

CERTIFICATE

This is to certify that the thesis entitled “Thermodynamic, economic analysis and designing of heating system for the swimming pool present at NIT Rourkela” submitted by Priyanka Tiwari (107CH034) in partial fulfilment for the requirements for the award of Bachelor of Technology Degree in Chemical Engineering at National Institute of Technology, Rourkela (Deemed University) is an authentic work carried out by her under my supervision and guidance.

To the best of my knowledge, the matter embodied in the thesis has not been submitted by any other University/Institute for the award of any Degree or Diploma.

Date:

Professor. S.K Agarwal
Department of Chemical Engineering
National Institute of Technology
Rourkela-769008

ACKNOWLEDGEMENT

I am extremely thankful to Professor S.K. Agarwal for giving me an opportunity to work on such an interesting live project which gave me an indepth understanding of the way in which practical work is carried out. I express my sincere gratitude to the suggestions, guidelines and feedback given by him which helped me in doing the project successfully. I am grateful to him for his critical analysis of every problem I discussed with him.

I extend my thanks to Professor R.K. Singh and Professor H.M. Jena for providing me with an opportunity to work on this project.

I am very thankful to Mr. Santosh Naik, swimming trainer, ASF, NIT Rourkela who helped us in recording the pool temperature and providing us with the details of the pool.

Date:

Priyanka Tiwari

107CH034

ABSTRACT

The swimming pool at NIT Rourkela, presently, has no heating system to heat the pool water during winters. Therefore, it is rendered unused during winters. The focus of this project is on designing an efficient and economically viable system to heat the swimming pool. Temperatures of pool water and air above the surface of pool water were recorded for the month of November (2010). Using this data, losses associated with the pool were calculated and were found to agree completely with the literature data. Three systems were proposed based on: heat pumps, natural gas heaters and solar based water heating system. A design has been proposed for solar based water heating system. Many models of heat pumps were considered and a detailed cost analysis was made. For natural gas heaters, different models were considered and cost analysis was carried out. Annual operating cost of heat pumps and natural gas heaters were compared and natural gas heaters were found to be about 1.8-3 times costlier than heat pumps. A combination of solar heating and a conventional heater in equal proportion has been proposed for a perfect heating system. Thermodynamic and economic analysis and designing of different systems for pool heating has been carried out in this work

CONTENTS

CHAPTER NO		TOPIC	PAGE NO
		Abstract	4
		List of figures	7
		List of tables	8
		Nomenclature	9
1		Introduction	10
2		Literature review	13
	2.1	Heat losses associated with the swimming pool	14
	2.2	Methods to heat the swimming pool	18
	2.3	Previous work done on swimming pool heating by researchers	29
3		Experimental	34
	3.1	Tabulation of temperature during winters	35
	3.2	Evaluating losses from swimming pool using the experimental data	39
	3.3	Design parameters for a heating system based on heat pumps	40
	3.4	Design of solar panel for heating system	41
	3.5	Design parameters using gas heaters for heating swimming pool water	42
4		Sample calculations	43
	4.1	Pool water volume calculation	44
	4.2	Calculation for heat requirement by pool for a 10 degree rise in temperature	45
	4.3	Sample calculations of heat losses using equations developed by Brambley	46
	4.4	Sample calculation for the operating cost of a heat pump	49
	4.5	Sample calculation for the operating cost of a gas heater	50
5		Designing of heating systems using different sources	51
	5.1	Designing of heating systems based on heat pumps	52
	5.2	Designing of heating system based on solar energy	53
	5.3	Designing of heating system based on gas heaters	54
6		Results and discussions	55
	6.1	Monthly variation of pool water and ambient air temperature at different times in a day	56
	6.2	Determination of losses from temperature data	59
	6.3	Economic analysis of heat pump based water heating system	63
	6.4	Economic analysis of natural gas heater based water heating system	66
	6.5	Cost comparison between heat pumps and natural gas heaters	67
	6.6	Designing of water heating system based on solar energy	69

7		Conclusions	71
		Scope for future work	73
		References	74

LIST OF FIGURES

FIGURE NO	FIGURE CAPTION	PAGE NO
1	A view of swimming pool at NIT Rourkela	12
2	%of various losses in a pool	17
3	Schematic diagram of a gas heater	18
4	Schematic diagram of a heat pump	20
5	Schematic diagram of a solar water heating system	24
6	Schematic diagram of an electric resistance heater	25
7	Pool cover	27
8	Solar sun ring	28
9	Design of the proposed solar panel	41
10	Schematic diagram of swimming pool at NIT Rourkela	44
11	Flowsheet showing heat pumps as heating medium	52
12	Flowsheet of solar panel being used as heating medium	53
13	Flowsheet showing natural gas heater being used as heating source	54
14	Variation of pool water and air temp with each day of month at 6:00am	56
15	Variation of pool water and air temp with each day of month at 7:30am	57
16	Variation of pool water and air temp with each day of month at 9:00am	57
17	Variation of pool water and air temp with each day of month at 12:00 noon	58
18	Variation of pool water and air temp with each day of month at 4:00pm	58
19	% contribution of each loss on 8 th November	60
20	% contribution of each loss on 12 th November	61
21	% contribution of each loss on 13 th November	61
22	% contribution of each loss on 14 th November	62
23	% contribution of each loss on 19 th November	62
24	Plot of KW rating Vs monthly operating cost	65
25	Plot of KW rating Vs no. of units required	65
26	KW rating Vs monthly operating costs and no. of units required	67
27	Cost comparison between heat pumps and natural gas heaters	69
28	Flow sheet showing the connections of the solar panel and its basic design	70

LIST OF TABLES:

TABLE NO.	TABLE CAPTION	PAGE NO.
1	Pool and air temperature at 6:00am and 6:40am for November	35
2	Pool and air temperature at 7:30am and 9:00am for November	36
3	Pool and air temperature at 12:00 noon and 4:00pm for November	37
4	Specifications of heat pumps used in designing the system and economic analysis	40
5	Specifications of natural gas heaters used in designing and economic analysis	42
6	Losses calculation at 12:00 noon	59
7	Cost analysis and no. Of unit required for each model	64
8	Monthly operating costs and no. of units required for each model of gas heater	66
9	Cost comparison between heat pumps and natural gas heaters	68

NOMENCLATURE

A	Area of the swimming pool (m^2)
C_1	Constant ($=8.87 \cdot 10^{-5} \text{ KW}/m^2\text{-Pa}$)
C_2	Constant ($=7.78 \cdot 10^{-5} \text{ KW}/m^3\text{-Pa}$)
C_p	Specific heat capacity (KJ/Kg degree Celsius)
h	Convective heat transfer coefficient (W/m^2 degree Celsius)
h_{fg}	Latent heat of vaporization (KJ/Kg)
m	Mass (Kg)
m^*	Evaporation mass flux density from surface of pool ($Kg/s\text{-m}^2$)
$P_{v,s}$	Partial pressure of water vapour at pool surface (Pa)
$P_{v,e}$	Vapour pressure of water far from surface (Pa)
Q_{cond}	Heat loss due to conduction (KW)
Q_{conv}	Heat loss due to convection (KW)
Q_{eva}	Heat loss due to evaporation (KW)
Q_{rad}	Heat loss due to radiation (KW)
Q_{total}	Total heat loss (KW)
T_a	Temperature of air far from pool (degree Celsius)
T_g	Temperature of the ground (degree Celsius)
T_s	Temperature of water at the surface of pool (degree Celsius)
U	Average overall conduction heat transfer coefficient (W/m^2 degree Celsius)
t	Temperature

GREEK SYMBOLS:

σ	Stefan Boltzman constant ($=54.67 \cdot 10^{-8} \text{ W}/m^2 \text{ K}^4$)
v	Air velocity (m/s)
Δ	Difference

CHAPTER 1

INTRODUCTION

Introduction:

NIT Rourkela has a great recreation centre in the form of the swimming pool housed in its campus. Students, faculties and staff enjoy the benefits of swimming pool which not only provides a great source of fun and enjoyment but also is a great way to remain healthy and fit.

Presently, the swimming season available in the pool is from March to November. The reason for its unavailability during peak winter months is the absence of a heating system to heat the pool water. The pool is therefore rendered unused in the winter season.

To extend the benefits of swimming pool throughout the year, a heating system needs to be installed in the pool which can provide a comfortable swimming temperature during winters.

OBJECTIVE OF THE PROJECT:

- The aim of this project is to design a heating system for the swimming pool which is both effective in heating as well as cost effective.
- Different methods available to heat a swimming pool needs to be thoroughly reviewed and their advantages and disadvantages studied properly to have a perfect heating system.
- Losses associated with the pool needs to be calculated to get a view of % loss contribution of every loss and take measures accordingly.
- Cost analysis of different system needs to be done to assess their economic viability as a heating medium.
- Designing a system based on renewable energy to minimize the dependence on conventional heaters.

The dimensions of the Institute swimming pool are:

Length: 50metre

Width: 22metre

Depth: 1.8metre (i.e. 6 feet) for the first 25 metres of length which gradually decreases to 0.9metre (i.e. 3feet) for the next 25 metres of length.



Figure 1: A view of swimming pool at NIT Rourkela.

CHAPTER 2

LITERATURE REVIEW

2.1 HEAT LOSSES ASSOCIATED WITH THE SWIMMING POOL:

1. EVAPORATIVE LOSSES: ^{[1],[2]}

This is a latent heat loss which accounts for the maximum heat loss from any swimming pool. This loss occurs when the surface water on pool gets converted to vapour state and gets carried away by the air. The basic reason for this latent heat loss is the fact that the partial pressure of ambient air is lower than the saturation vapour pressure at pool temperature. Both diffusive and conductive mass transfers are the mechanism involved in the vaporisation process. This loss constitutes about 70% of the total heat losses from the pool, both indoor and outdoor pool. There are many correlations available in literature to calculate evaporative losses.

Factors affecting evaporation rate are:

- Temperature of pool
- Air temperature
- Humidity
- Wind speed at the surface of pool.

Evaporation rate is increased by:

- High wind speed
- Low pool water temperature
- High air temperature
- Low relative humidity

2. CONVECTIVE LOSSES: ^{[1],[2]}

This is a sensible heat loss and is closely linked with evaporative losses. This loss is associated with the temperature difference between pool water and the surrounding air. There is a dominance of natural convection rather than forced when the water or air velocities are negligible. Evaporation is an enhancing factor in increasing the natural convection as it is associated with creating differences in the density of air. There is no sensible heat loss by convection when the temperature of air and water is equal. There are various correlations available in the literature to predict the convective heat loss.

The factors affecting the convective heat loss are:

- Wind speed
- Air temperature
- Pool water temperature

Convection losses are enhanced by:

- High wind speed
- Low air temperature
- High pool temperature

3. RADIATION HEAT LOSS: ^{[1],[2]}

This loss occurs when the warmer pool radiates heat to cooler sky. By the method of infrared radiation exchange, heat is transferred from the pool surface to sky. Air is the transparent medium in this exchange process.

Net radiative heat loss from pool surface to air = radiation emitted from pool- (reflected radiation+infrared radiation emitted by walls that is absorbed by pool).

There are many equations available to determine the radiative heat losses. To use the formulas, emittance of the water, air and pool surface must be known.

Radiative heat loss consists of about 20-30% of the total heat loss in outdoor pools.

Factors affecting radiation heat loss are:

- Sky conditions
- Humidity
- Pool temperature

Radiative losses are increased by:

- Clear sky
- Low relative humidity
- High pool temperature

4. LOSSES DUE TO CONDUCTION: ^{[1],[2]}

These constitute a very small percentage of the total losses associated with the pool. Conduction losses are through the bottom and sides of the pool. Standard Heat transfer equation can be used to assess this loss.

This loss is increased by:

- High wind speed
- High pool temperature

- Low air temperature

5. LOSSES DUE TO GROUND: ^{[1],[2]}

For an in ground pool, these losses are less than 10% of the total heat loss since ground is a good insulator.

We can see the percentage of all the losses in the following pie chart:

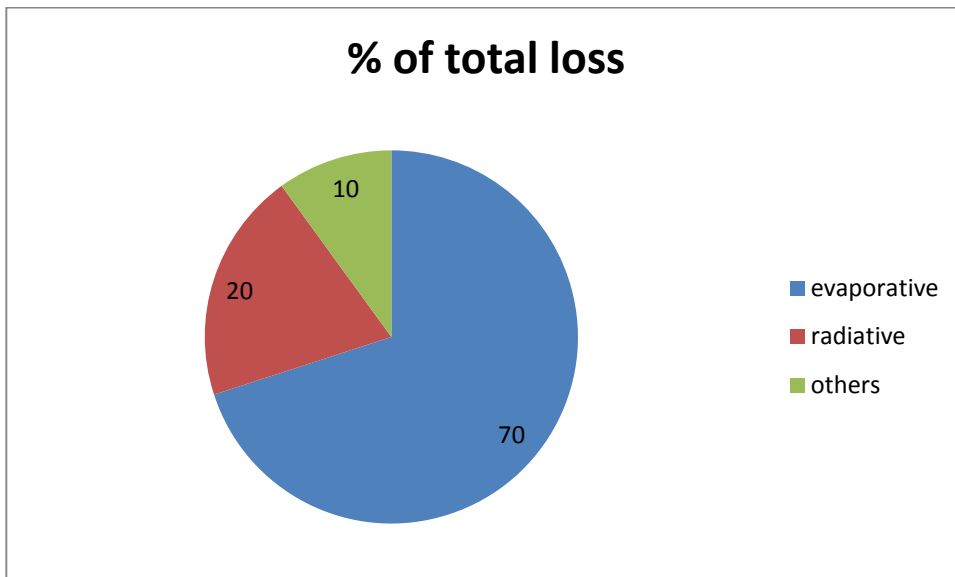

Figure 2: %of various losses in a pool.

2.2 METHODS TO HEAT THE SWIMMING POOL:

(A) Use of Active devices:

(1) GAS HEATING

Gas heaters burn propane or natural gas to heat the pool. This is one of the most widely used methods to heat the pool. Gas heating is very efficient.

Working:^[16]

The gas heater consists of a number of finned copper tubes running back and forth above a burner tray. On the burner tray, gas is ignited to warm the copper tubing and water from the filtration chamber is passed through. The pool water absorbs heat as it passes through the heated copper tubing and is then returned to the pool. This is the basic principle of gas heating. Heat exchanger is the main part of these heaters.

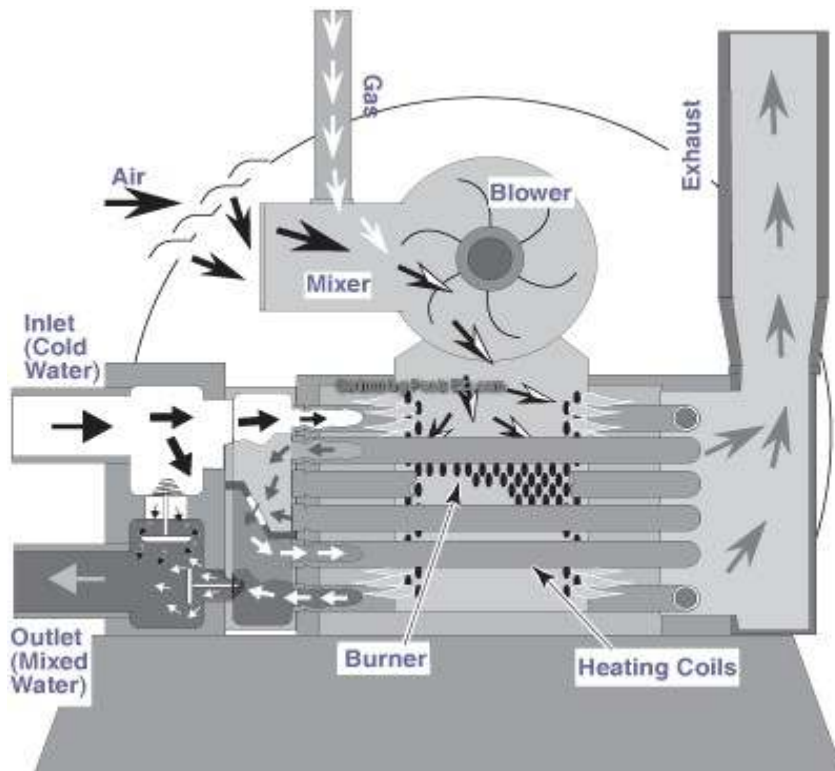

Figure 3: schematic diagram of a gas heater.^[17]

Advantages of gas heating:

- Gas heaters are available widely in different sizes and prices.
- Can heat up the pool water upto any desired temperature in any weather conditions.
- Least polluting of all the fossil fuels.
- Provides heating according to need and efficiently.

Disadvantages of gas heating:

- High operating cost.
- It uses the fast depleting fossil fuel i.e. natural gas which contributes in the environmental problems of the world.

(2) HEAT PUMP

It is also a widely used method to heat the swimming pool water. These heat pumps take the heat out from outside air and divert this heat to the pool. For every unit of electricity consumed, heat pumps generate three to five units of usable energy.

Working: ^[18]

The heat pump consists of:

- Evaporator air coil
- Heat exchanger
- Compression and expansion valves
- Refrigerant (R-22 or R-12)

Heat pump fan circulates air through the outer evaporator air coil that acts as a heat collector. The liquid refrigerant present in the air coil absorbs this heat and gets converted to gaseous state. This gaseous refrigerant is then pumped by the compressor into the heat exchanger. This warm gas intensifies the heat and thus the heat is exchanged between the warm refrigerant gas and the relatively cool pool water. After heat exchange, the refrigerant reverts back to its liquid state, and is pumped into the expansion valve into the evaporator air coil.

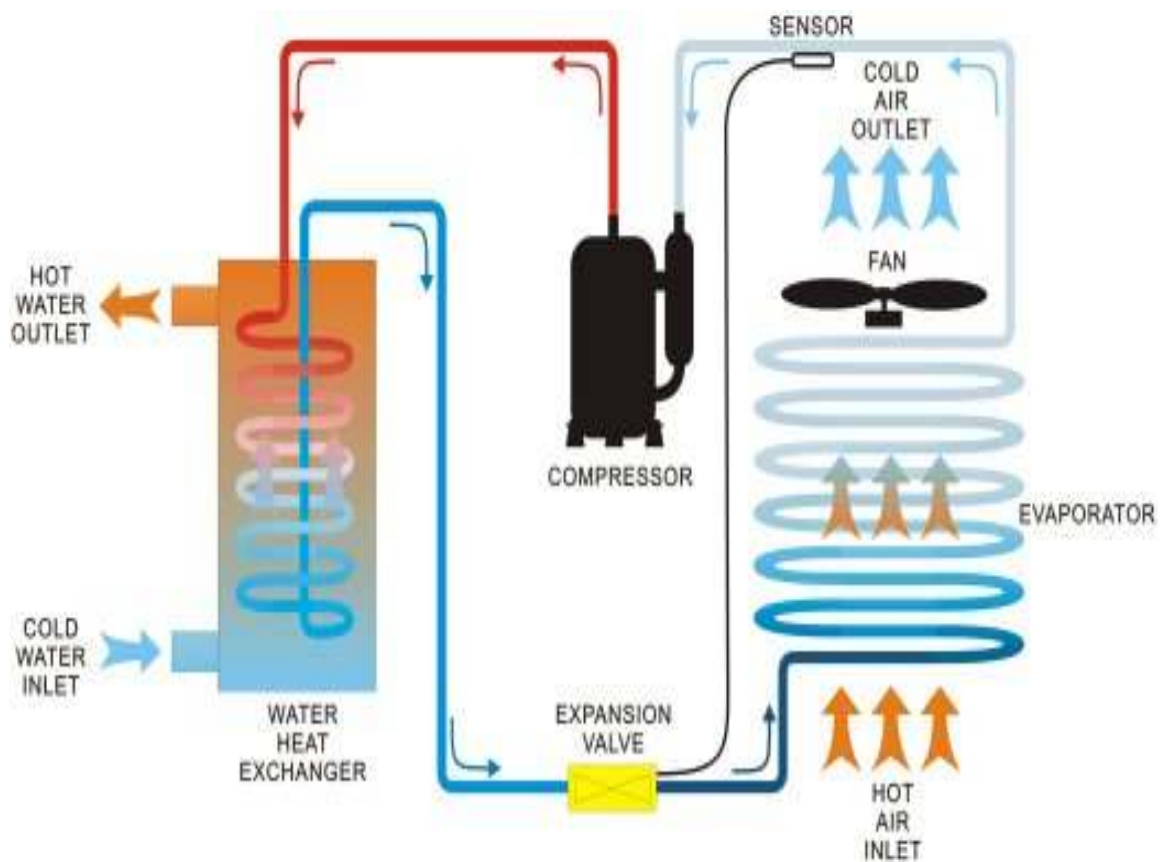

Figure 4: schematic diagram of a heat pump.^[18]

Coefficient of performance (COP) of a heat pump determines the efficiency of the heat pump.

Generally it ranges from three to five for the heat pumps.

Advantages of a heat pump:

- Provides heat whenever required and is highly efficient.
- Is cheaper than a gas heater and an electric resistance heater.

Disadvantages of a heat pump:

- Uses CFC's (chloro fluoro carbons), which is a major contributor to the ozone layer depletion. Therefore it is harmful to the environment.
- Heats slowly as compared to a gas or an electric resistance heater.
- High costs involved.

(3) SOLAR WATER HEATING SYSTEMS ^[19]

Heating of swimming pool by the use of solar energy is one of the most environment friendly ways for heating. Though solar systems are not very commonly used systems to heat the pool, but once installed properly they can be very economical and efficient.

Solar Water Heating Systems

- ❖ **Active:** one which requires electric power for its operation.
- ❖ **Passive:** relies on natural forces to operate.
- ❖ **Direct:** heats the water directly in the collector.
- ❖ **Indirect:** heats another fluid and transfers this heat to water.

Working:

Sun heats up the absorber surface present inside a solar collector. A heat transfer fluid or water to be heated itself flows through tubes attached to the absorber and gets heated up. This heated water is stored in a separate water heater tank, so that the heated water can be used when required.

There are various systems designed based on usage:

Low Temperature systems: operates at about 10 degree Celsius above the ambient temperature. Used for heating swimming pools.

Mid Temperature systems: operates at 10-50 degree Celsius above the outside temperature. Used for domestic water heating.

High Temperature systems: these are mostly used for absorption cooling or electricity generation.

The various components of solar water heating systems are:

Solar Collectors: these are the main components of a solar water heating (SWH) system. They collect and concentrate the solar energy and transfer this heat to fluids. Unglazed collectors generate small temperature rise and are fit for

low temperature applications. For higher temperatures,
glazed collectors are required.

Thermal Storage: tanks are used as storage devices to store heated water.

Controller system: controllers are used to read the temperatures and give
instructions accordingly to other devices to start or stop
functioning.

In the case of SWH systems, a backup heater(based on gas or electricity as source) can be used so that hot water is supplied even in absence of sunny days.

Advantages of SWH systems

- Renewable source of energy.
- Non polluting energy source.
- Low operating cost.
- Best source for heating swimming pool without wasting gas or electricity.

Disadvantages of SWH systems

- Lot of space required for solar panel installation.
- In the absence of sun, no heating, therefore the need of fossil fuel heater arises.
- SWH systems don't provide heat on demand.

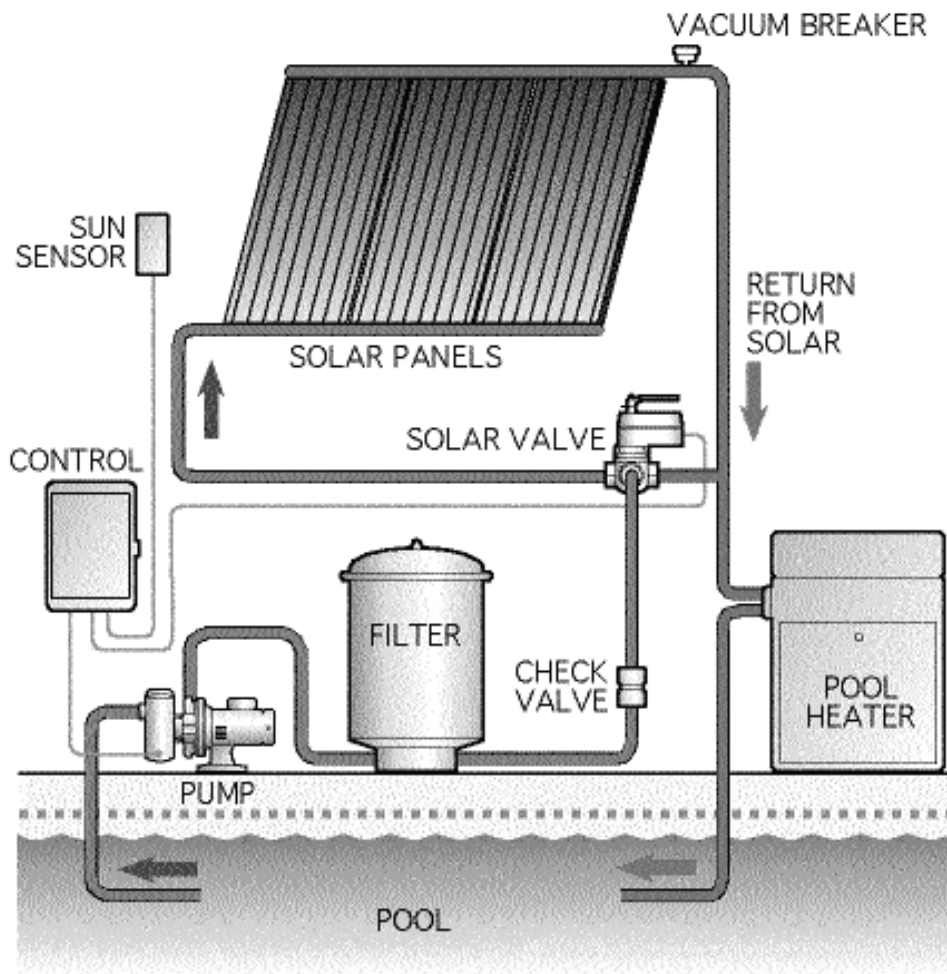

Figure 5: schematic diagram of a solar water heating system. [20]

(4) ELECTRIC RESISTANCE HEATERS

These are the typical heaters which use electricity as input to heat the pool water. These are the direct type pool heating device and have a heater inside them which heats up the pool water.

Advantages:

- Electricity is available throughout the year, everywhere.
- These heaters are flameless and provide heat on demand.

Disadvantages:

Electricity is very costly. These heaters consume a lot of electricity.

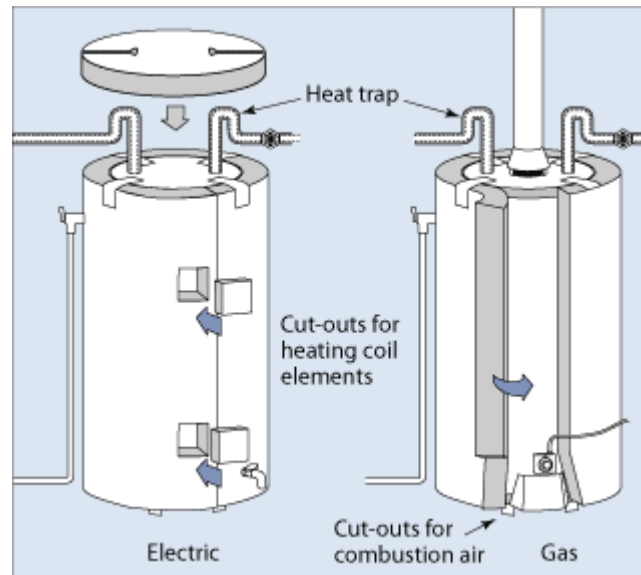

Figure 6: schematic diagram of an electric resistance heater. ^[21]

(B) Use of Passive Devices:

1 USE OF SWIMMING POOL COVERS:

Pool covers essentially are large sheets that cover the surface of pool. The maximum heat loss occurs from the surface of pool in the form of evaporative heat loss. If this heat loss can be restricted, a lot of energy can be saved to heat the pool. Pool covers serve this purpose of

reducing the evaporative heat loss. Savings of about 50-70% on heating the pool can be obtained by using a pool cover.

Advantages of a pool cover:

- It reduces the evaporative heat loss effectively.
- Reduces heating costs upto 50-70 %.
- It also restricts pool water from getting evaporated thus saving the amount of make up water required.
- It also reduces the chemical consumption of pool.

Materials used for making pool covers:

- UV stabilized polyethylene.
- UV stabilized polypropylene.
- UV stabilized vinyl.

Pool covers can be:

- Transparent
- Opaque
- Translucent

Modes of operating a pool cover:

- Manually
- Semi automatic using a motor driven reel system.
- Automatic having permanently mounted reels.

Mechanism of working of a pool cover:

These covers are made up of tiny air pockets which hold the heat gathered from the sun. This heat is then slowly released. These pockets help in heating the pool to its greatest depths. These air pockets come in different shapes like diamond and circle shapes. Cover having diamond pockets will hold more heat as these pockets will be closed together. Cover having circular pockets will be further apart and will not hold so much heat as in case of diamond pocket.



Figure 7: pool cover

The performance of a pool cover depends on:

- Thickness of cover.

- Colour of cover.
- Shape of air pockets.
- Efficiency of operating pool cover and its maintenance.

2 SOLAR SUN RINGS ^[22]

Solar rings are made of two sheets of heavyweight UV resistant vinyl. The upper air holds the insulating air and it focuses sunlight on blue coloured lower layer. This blue layer absorbs fifty percent of sunlight and converts it to heat. Rest of the sunlight passes through for deep water heating. The air trapped acts as an insulating blanket at night and retains the heat.

These rings can decrease evaporation, help in heating the pool water and help save chemicals required by the water.

These rings will help in reducing costs of heating pool and will prove economical in long run.



Figure 8: solar sun ring. ^[23]

2.3 PREVIOUS WORK DONE ON SWIMMING POOL HEATING BY RESEARCHERS

BRAMBLEY AND WELLS (1983) ^[1]

They have suggested various equations to calculate the heat losses associated with a swimming pool. They have developed equations to assess various losses like:

Convective heat loss:

$$q_{\text{conv}} = h(T_s - T_a)$$

Evaporative heat loss:

$$q_{\text{eva}} = (m^*) * (h_{fg})$$

Radiative heat loss:

$$Q_{\text{rad}} = \sigma(T_w^4 - T_a^4)A$$

Conductive heat loss:

$$Q_{\text{cond}} = U * A * (T_w - T_g)$$

They have devised several ways to reduce cost of heating. They have analysed ventilation rates, solar heating systems, pool covers to reduce costs in different conditions like when:

$T_w > T_a$ or when: $T_a > T_w$.

MATUSKA et.al. (2009) ^[3]

They have developed Kolektor 2.2, a mathematical model and designing software, which is an improvement over the previous designing models. This model is used for designing solar flat plate collectors. The model developed has been experimentally validated for different construction designs of tested solar collectors. After validation, this designing tool can be used for designing and virtual prototyping of new flat plate solar collectors. A reference solar flat plate collector was used for analysis.

MISHRA (1993) ^[4]

In this paper, hybrid solar air and water heating systems have been developed. Performance equations have been developed. Equations developed are for collection efficiency in terms of design parameters for air and water heating systems. These equations have been experimentally verified. Transient analysis for open and closed loop cycle has been done. Techno-economic evaluation has been done for these systems keeping in mind the Indian market.

ALKHAMIS et.al. (1992) ^[5]

Simulation software TRNSYS has been used for conducting feasibility studies of a solar assisted heating system. A thermodynamic as well as an economic analysis has been done for the Aquatic centre at University of Miami. The effect of collector area on different systems

and sub-systems was studied. Economic analysis was done by keeping in mind the fuel prices and inflation.

SINGH et.al. (1989) ^[6]

A transient analysis of an indoor swimming pool has been done which is connected to a panel of collectors. Based on this, an explicit equation was developed for the pool water temperature. To validate the model, calculations were done for an Australian swimming pool under active and passive mode of operation. The developed equation can be used for optimization.

FRANCEY et.al. (1980) ^[7]

In this paper, the effect of using a pool cover on energy savings has been studied. Two systems were compared, one with pool cover on it and one without a pool cover. Covers of different material were used for experimenting and different effects were studied. Pool covers were found to be economical and were effective in reducing heat loss.

LUMINOSU (2004) ^[8]

For constant maintenance of temperature and efficiency of solar collector, flow of the thermo fluid needs to be modified. An analytical and numerical study has been done on the temperature and efficiency equations. Experimental verifications for the numerical study

were done. The method developed allows the establishment of technical and constructive parameters of a flat plate solar collector.

FRANCEY et.al. (1981) ^[9]

Solar radiation was measured and absorption characteristics of solar radiation were studied. A number of optical tests were done on pool covers to determine the characteristics of different types of pool covers. The transmission characteristics of pool covers were determined. It was determined that pool covers were useful in maintaining elevated water temperature.

YADAV AND TIWARI (1987) ^[10]

In this paper, a transient analysis of swimming pool, with and without pool cover, with and without heat exchanger has been done. For each of the above cases, equation for pool water temperature has been determined. For testing the equations, experimental data was employed. The experimental results were in good agreement with the numerical analysis.

HAAF et.al. (1994) ^[11]

In this paper, the general energy model was elaborated for open air swimming pools. In the general model, parameters defined with the optimization model were integrated. The developed model was validated with different swimming pools. The validated model was integrated in a user friendly programme which can be used by design engineers.

KAYALI (1998) ^[12]

In this work, different types of domestic water heating systems are compared with each other. These systems include thermosiphons, geysers, flat plate collectors and solar ponds. An economic analysis has been done for all these and their annual total costs were compared. In long term, solar based heating proved to be the most economical.

KIM et.al (2008) ^[13]

In this paper, thermal performance of a compound parabolic concentrator has been evaluated. A numerical analysis was done for the simulation of experimental set up. Two types of models of compound parabolic concentrator –stationary and tracking were studied and their thermal efficiency was determined.

LEE et.al (2008) ^[14]

Optimization of heat pump design has been carried out in this paper. To reduce the cost, swarm algorithm has been used for optimizing the heat pump. An indoor swimming pool has been used for optimization and different continuous and discrete parameters were optimized.

CHAPTER 3

EXPERIMENTAL

EXPERIMENTAL:

3.1 TABULATION OF TEMPERATURE DURING WINTERS.

To assess the temperature pattern during winter season, temperature of air above the pool and pool temperature were recorded during the month of November at six different times in a day.

All temperatures are in degree Celsius.

Table 1: pool and air temperature at 6:00am and 6:40am for November.

DATE	T _w (6:00 am)	T _a (6:00am)	T _w (6:40am)	T _a (6:40am)
2	25	21	25	22
3	25	22	24	22
4	27	25	25	23
5	24	23	24	21
6	25	22	24	21
7	25	21	24	23
8	24	22	23	22
9	25	23	26	24
10	25	22	26	25
11	24	21	26	24
12	25	22	27	23
13	27	23	28	22
14	26	25	27	25
15	27	25	27	26
16	27	26	27	27
17	26	25	26	27

18	27	25	25	26
19	27	26	28	27
20	28	26	28	27
21	28	26	25	26
22	25	16	25	16
23	25	23	26	24
24	25	24	26	25
25	24	26	27	25
26	27	29	28	26
27	26	28	28	27

Table 2: pool and air temperature at 7:30am and 9:00am for November.

DATE	T _w (7:30am)	T _a (7:30am)	T _w (9:00am)	T _a (9:00am)
2	24	23	25	30
3	23	22	24	29
4	24	23	26	28
5	27	26	25	27
6	26	24	26	28
7	24	29	23	29
8	26	24	26	24
9	28	28	28	25
10	30	27	26	28
11	26	24	27	25
12	25	23	27	26

13	24	22	26	24
14	28	24	30	28
15	28	27	28	26
16	27	26	28	27
17	28	27	29	27
18	28	27	30	31
19	28	26	30	31
20	30	28	30	31
21	30	36	29	28
22	25	16	28	27
23	25	26	30	31
24	28	29	28	27
25	26	25	29	28
26	30	31	30	31
27	28	27	28	27

Table 3: pool and air temperature at 12:00 noon and 4:00pm for November.

DATE	T _w (12 noon)	T _a (12 noon)	T _w (4:00 pm)	T _a (4:00 pm)
2	26	31	25	22
3	25	32	24	21
4	27	32	26	22
5	28	31	25	21

6	29	30	25	22
7	28	31	27	22
8	27	25	28	23
9	29	31	29	28
10	30	32	-	-
11	29	31	30	31
12	32	28	28	30
13	32	30	27	25
14	31	30	28	29
15	30	32	27	25
16	30	31	28	27
17	29	30	27	28
18	32	35	27	25
19	30	28	28	26
20	30	32	28	26
21	30	32	28	27
22	30	28	26	30
23	31	32	27	29
24	30	39	26	24
25	30	32	28	26
26	35	35	29	30
27	32	35	28	30

3.2 EVALUATING LOSSES FROM SWIMMING POOL USING THE EXPERIMENTAL DATA:

The above data was used in calculating the losses associated with the pool. Equations developed by Brambley^[1] were used in calculating the losses.

The equations used are:

$$Q_{\text{conv}} = h * A * (T_s - T_a)$$

$$Q_{\text{rad}} = \sigma * A * (T_w^4 - T_a^4)$$

$$Q_{\text{cond}} = U * A * (T_w - T)$$

$$Q_{\text{eva}} = (m^*) * h_{\text{fg}} * A$$

$$Q_{\text{total}} = Q_{\text{conv}} + Q_{\text{rad}} + Q_{\text{cond}} + Q_{\text{eva}}$$

After calculating each loss and doing summation of all the losses, percentage contribution of each loss to the total heat loss was calculated. Then pie charts were plotted to see the contribution of each loss.

The obtained percentages of each loss were compared to the losses contribution as given in literature.

3.3 DESIGN PARAMETERS FOR A HEATING SYSTEM BASED ON HEAT PUMPS:

A heating system has been designed with heat pumps as the heating source. Economic analysis has been done using these. Heat pump takes electricity as input but utilize the surrounding air to extract heat. It is one of the most efficient systems for heating but it contributes in ozone layer depletion.

Specifications of heat pumps used in designing:

Different heat pumps were used for designing the system and for economic analysis.

Different heat pumps and their specifications are given below:

Table 4: specifications of heat pumps^[24] used in designing the system and economic analysis.

MODEL NO.	KW RATING	COP
AWHNHP10N	12	4.17
WWHCNHP10 D.S.	12	6.25
AWHNHP12.5 N	13.5	4.63
WWHCNHP12.5 D.S.	13.5	6.96
AWHNHP25 N	26	4.75
WWHCNHP25 D.S.	26	7.15
AWHNHP50 N	52	4.75
WWHCNHP50 D.S.	52	7.6

Using the above details, economic analysis was carried out.

3.4 DESIGN OF SOLAR PANEL FOR HEATING SYSTEM BASED ON SOLAR WATER HEATING (SWH)

A solar panel was designed to heat the water in swimming pool.

A picture of the designed solar panel is given below. In this design, plywood is used as a base. A rectangular piece is attached to the plywood in the middle. Around this small centre piece, a pipe of 1 inch has been coiled. Some part of the starting part of the coil has been taken out. The end part of the coil is taken towards one side corner of the base. Thin wood sticks have been used to keep the coiled pipe in place.

This is not a working model. No experiments have been conducted using this model. This model represents the actual design layout of the solar panel intended to be used in heating.



Figure 9: design of the proposed solar panel.

3.5 DESIGN PARAMETERS USING GAS HEATERS FOR HEATING SWIMMING POOL WATER

Gas heaters have been considered to heat the pool water. Models of different efficiency and heat capacities have been considered. Details of them are given below.

Table 5: specifications of natural gas heaters used in designing and economic analysis.

Model no.	Rating of heater (output) in Btu/hr	Input power (KW)	Efficiency (%)
1	150,000	55	80
2	150,943	52	85
3	75472	26	85
4	34833	12	85

Economic analysis has been carried out on the above models of gas heaters and their feasibility for pool water heating is discussed.

CHAPTER 4

SAMPLE CALCULATIONS

4.1 POOL WATER VOLUME CALCULATION

Length of pool = 50m

Width of pool = 22m

Depth of pool = 1.8m for first 25m of length which gradually decreases to
0.9m for the next 25m of length.

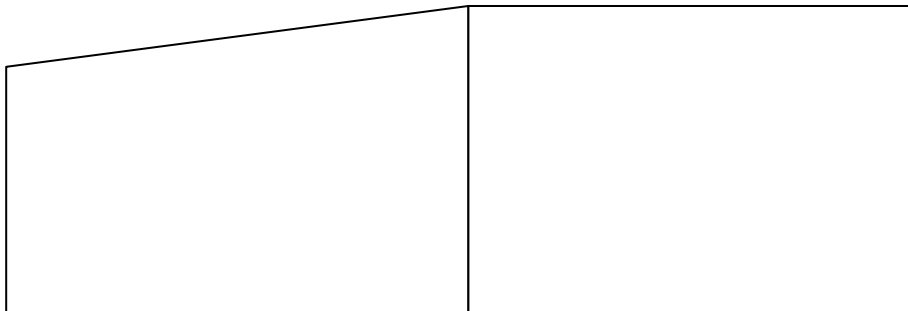

Figure 10: schematic diagram of swimming pool at NIT Rourkela.

$$\text{Volume of pool} = [(25 \times 1.8288) + \{0.5(1.8288 + 0.9144)\} \times 25] \times 22$$

$$= 1760 \text{ m}^3 = \text{volume of pool water}$$

$$\text{Area of the pool, } A = 50 \times 22 = 1100 \text{ m}^2$$

4.2 CALCULATION FOR HEAT REQUIREMENT BY POOL FOR A 10 DEGREE RISE IN TEMPERATURE

Density of water = 1000 kg/m^3

Specific heat capacity of water = $4.18 \text{ KJ}/(\text{Kg} \cdot \text{deg Celsius})$

$\Delta t = 10 \text{ deg Celsius}$.

Now , using the heat equation,

$$Q = m \cdot C_p \cdot \Delta t$$

$$m = (\text{density of water}) \cdot (\text{volume of water})$$

$$= 1000 \cdot 1760$$

$$= 176 \cdot 10^4 \text{ kg}$$

$$Q = (176 \cdot 10^4) \cdot (4.18) \cdot (10)$$

$$= 73,568,000 \text{ KJ}$$

If a heating period of 6 hours is assumed, power required to raise the pool temperature is:

$$73,568,000 / (6 \cdot 60 \cdot 60) = 3406 \text{ KW}$$

4.3 SAMPLE CALCULATION OF HEAT LOSSES USING EQUATIONS DEVELOPED BY BRAMBLEY ^[1]

Data point chosen for calculation:

Date : 12th November

Time : 12:00 noon

Assumptions:

Air velocity above pool surface (v) = 0.15 m/s

Overall heat transfer coefficient for conduction (U) = 0.57W/(m²*degree Celsius)

Evaporative heat loss:

$$Q_{\text{eva}} = (m^*) * h_{\text{fg}} * A$$

$$m^* = [(c_1 + c_2 v) / h_{\text{fg}}] * [P_{\text{v,s}} - P_{\text{v,e}}]$$

$$c_1 = 8.87 * 10^{-5} \text{ KW} / (\text{m}^2 * \text{Pa})$$

$$c_2 = 7.78 * 10^{-5} \text{ KJ} / (\text{m}^3 * \text{Pa})$$

On 12th November at 12 noon:

Pool water temperature = 32 degree Celsius

Air temperature = 28 degree Celsius

Partial pressure of water at pool surface ($P_{\text{v,s}}$) = 4743 Pa

Vapour pressure of water far from surface of water ($P_{\text{v,e}}$) = 3780 Pa

Area of the pool (A) = 1100m²

Putting the values, we get:

$$Q_{\text{eva}} = 106 \text{ KW}$$

Convective heat loss:

$$Q_{\text{conv}} = h * A * (T_s - T_a)$$

$$h = 3.1 + 4.1v^{[15]}$$

$$T_s = 32 \text{ degree Celsius}$$

$$T_a = 28 \text{ degree Celsius}$$

We get the convective heat loss as:

$$Q_{\text{conv}} = 16.34 \text{ KW}$$

Radiative heat loss:

$$Q_{\text{rad}} = \sigma * A * (T_w^4 - T_a^4)$$

$$\sigma = 5.67 * 10^{-8} \text{ W}/(\text{m}^2 * \text{K}^4)$$

$$T_w = 32 \text{ degree Celsius}$$

$$T_a = 28 \text{ degree Celsius}$$

Therefore, we get:

$$Q_{\text{rad}} = 27 \text{ KW}$$

Conductive heat loss:

$$Q_{\text{cond}} = U \cdot A \cdot (T_w - T_g)$$

$$U = 0.57 \text{ W}/(\text{m}^2 \cdot \text{degree Celsius})$$

$$T_w = 32 \text{ degree Celsius}$$

$$T_g = 28 \text{ degree Celsius}$$

We get:

$$Q_{\text{cond}} = 2.508 \text{ KW}$$

Total losses

$$Q_{\text{total}} = Q_{\text{eva}} + Q_{\text{conv}} + Q_{\text{rad}} + Q_{\text{cond}}$$

$$= 151.848 \text{ KW}$$

$$\% \text{ evaporative loss} = (Q_{\text{eva}}/Q_{\text{total}}) \cdot 100 = 69.8\%$$

$$\% \text{ convective loss} = (Q_{\text{conv}}/Q_{\text{total}}) \cdot 100 = 10.76\%$$

$$\% \text{ radiative loss} = (Q_{\text{rad}}/Q_{\text{total}}) \cdot 100 = 17.78\%$$

$$\% \text{ conductive loss} = (Q_{\text{cond}}/Q_{\text{total}}) \cdot 100 = 1.65\%$$

4.4 SAMPLE CALCULATION FOR OPERATING COST OF A HEAT PUMP

Assumption: heating cycle = 6 hours

Pump model no: AWHNHP25 N

Power rating of the pump: 26 KW

COP: 4.75

Cost of electricity = 2.5 Rs/KWh

KW rating of heat pump = 26KW

Hours /day heat pump is to be used = 6 hrs

Daily operating cost = $(2.5*26*6) = \text{Rs } 390/\text{day}$

Days in a month heat pump is used = 30

Therefore, monthly operating cost = $390*30 = \text{Rs } 11,700$ per month

Heat output given by 1 pump = $26*4.75 = 123.5 \text{ KW}$

Therefore, number of heat pumps of 26 KW rating (COP=4.75) required to raise the pool water temperature by 10 degree Celsius = $(3406/123.5) = 28$ nos.

4.5 SAMPLE CALCULATION FOR OPERATING COST OF A GAS HEATER

Cost per therm of natural gas = 0.525 \$/therm

(1therm = 10^5 Btu)

Btu/hr rating of natural gas heater = 150,000Btus/hr (=43.95 KW)

Efficiency of heater = 80% = 0.8

Therms/hr = $(150,000/0.8)/10^5 = 1.875$ therms/hr

(input energy = $150000/0.8 = 187500$ Btu/hr = 55KW)

Hrs per day heater is used = 6 hrs

Daily operating cost = $(0.525*1.875*6) = 5.9$ \$/day

Days in a month heater is used = 30

Monthly operating cost = $(5.9*30) = 177$ \$/month

Assuming: 1\$=50 Rs

Monthly operating cost = Rs 8850

No.of units required to raise the temperature of pool water by 10 degree Celsius in 6 hours =

$3406/43.95 = 78$

Total monthly operating cost of the whole natural gas heater installation = $(78*8850) = 6,90,300$ Rs.

CHAPTER 5

DESIGNING OF HEATING SYSTEMS USING DIFFERENT SOURCES

5.1 DESIGNING OF HEATING SYSTEM BASED ON HEAT PUMPS

In this particular system design, heat pumps have been used as the heating device for raising the temperature of the pool water. Different models of heat pump have been considered. Operating cost per month has been determined for each model. The number of units of heat pumps required to heat up the pool in 6 hours of each model has been calculated. Thus economic feasibility of easily available heat pumps has been determined.

Below is a flowsheet showing the installation of heat pumps in the pumping and filtration unit of swimming pool.

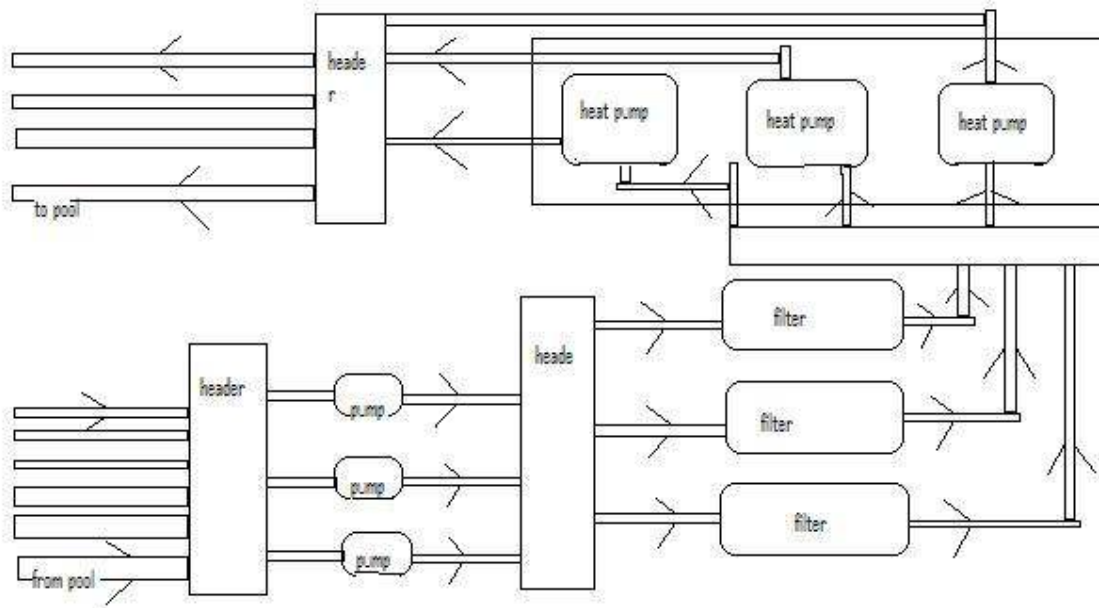

Figure 11: flowsheet showing heat pumps as heating medium.

5.2 DESIGNING OF HEATING SYSTEM BASED ON SOLAR ENERGY OR SWH SYSTEM

To make full use of the abundant solar energy available in Rourkela, solar panel has been designed. But this is not a 100% solar energy based heating system. The power required to heat the pool in six hours for a ten degree temperature rise is 3406 KW. Only 50% of this power required, i.e., 1703 KW will be generated by solar energy. The rest 50% power has to come from some other source like conventional heaters. This is done to avoid total dependence on solar energy and make the system more efficient. This hybrid system for heating of pool water will prove to be economical as well as efficient.

A schematic diagram of set up of solar panel and their connectivity with pumping and filtration is shown:

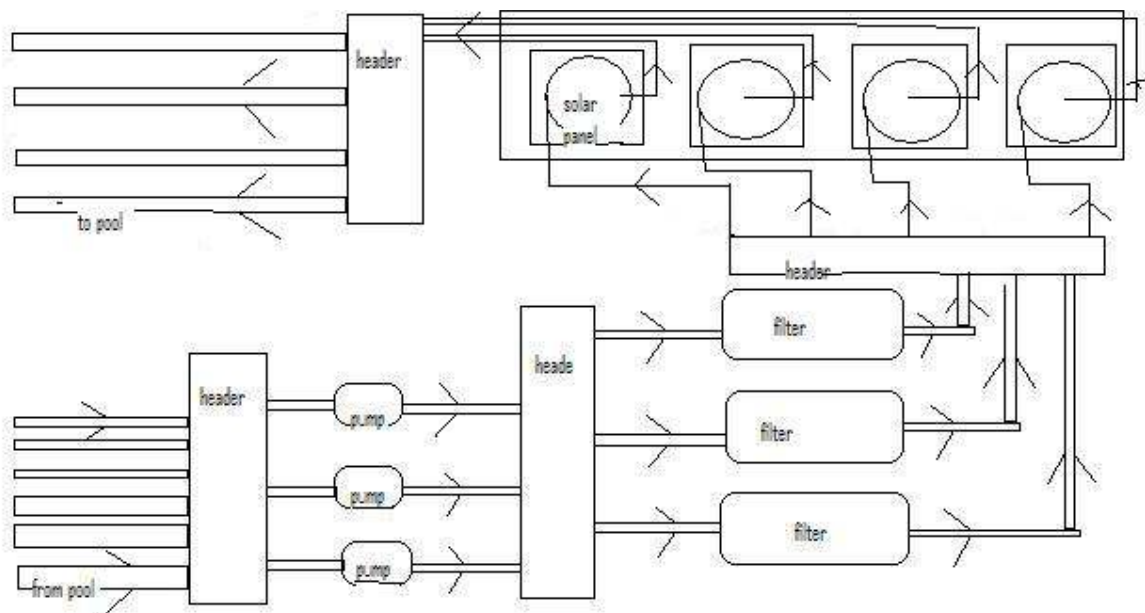

Figure 12: flowsheet of solar panel being used as heating medium.

5.3 DESIGNING OF HEATING SYSTEM BASED ON GAS HEATERS

Gas heaters are efficient in heating pool waters. But this is a costly method. Natural gas heaters are available easily. A flowsheet below shows the heating system based on natural gas heaters.

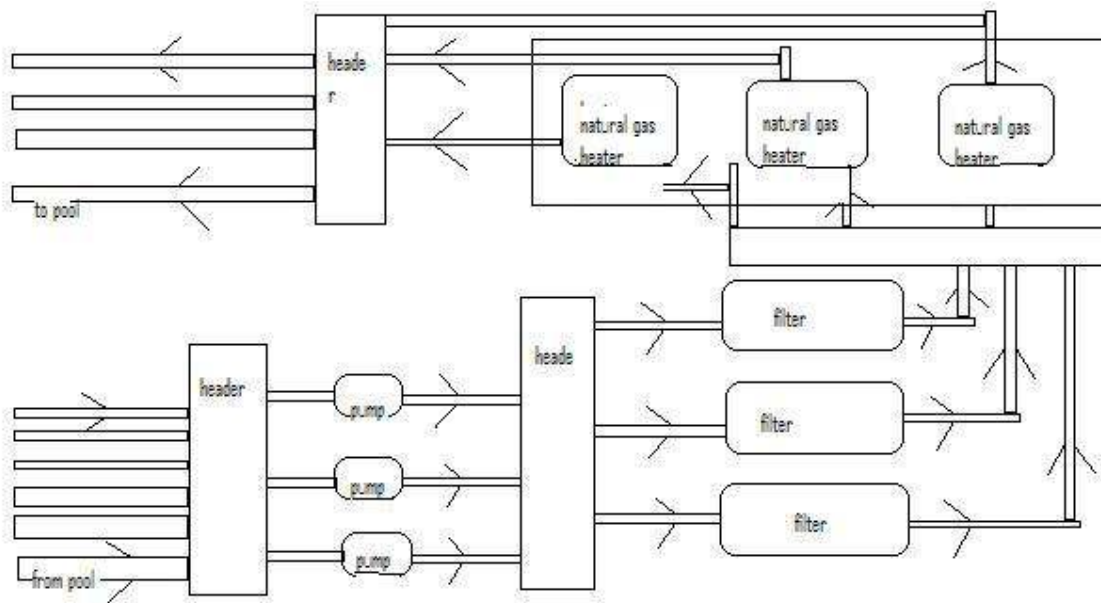

Figure 13: flowsheet showing natural gas heater being used as heating source.

CHAPTER 6

RESULTS AND DISCUSSIONS

RESULTS AND DISCUSSION

6.1 MONTHLY VARIATION OF POOL WATER AND AMBIENT AIR TEMPERATURE AT DIFFERENT TIMES IN A DAY:

Graphs have been plotted for the month of November showing the temperature variation of both pool water and air at different timings for which readings were recorded. Some observations are:

A wavy pattern was observed with small deviations from mean temperature.

Sharp peaks (up or downwards) were observed in some days.

Maximum 9 intersections (at 4:30pm) and minimum 1 intersection (at 6:00am) were seen between the temp curve of pool water and air in a month.

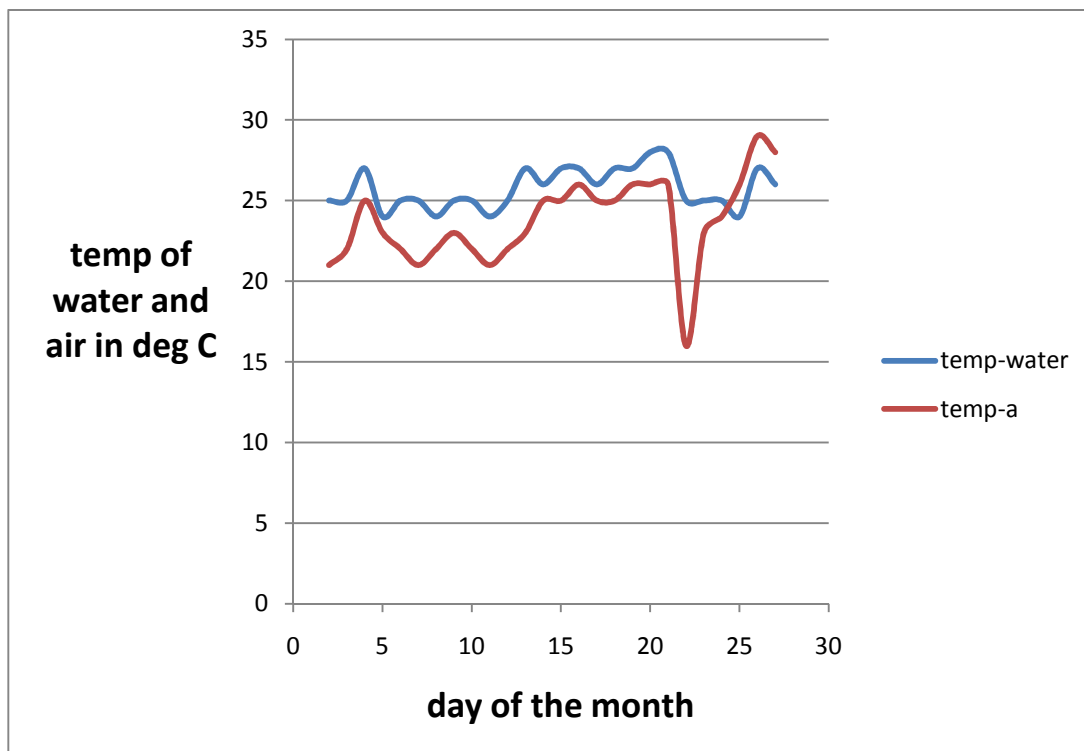

Figure14: variation of pool water and air temp with each day of month at 6:00am

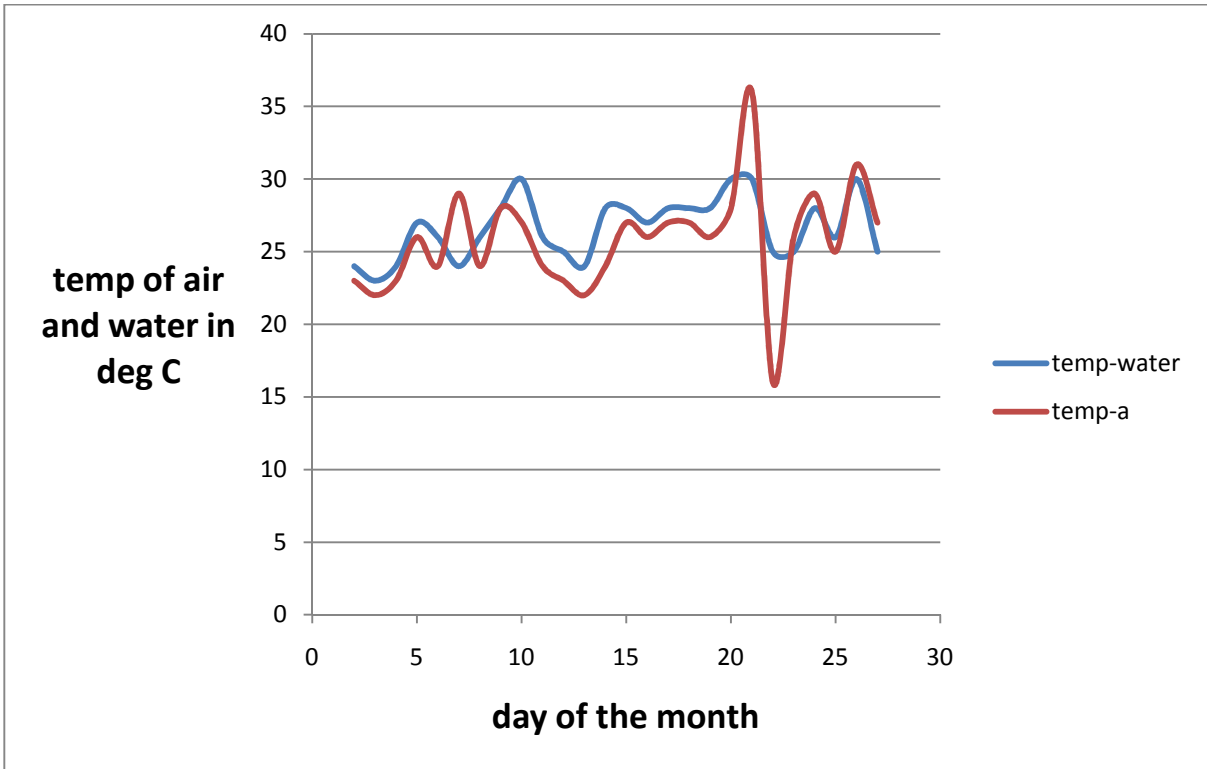

Figure 15: variation of pool water and air temp with each day of month at 7:30am

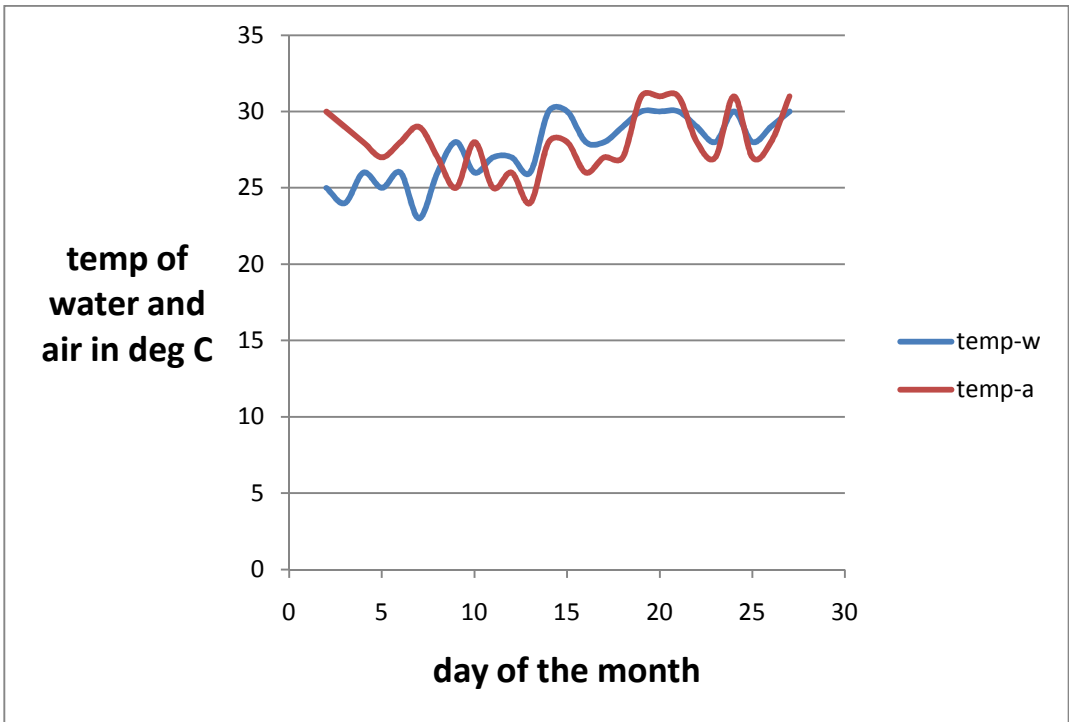

Figure16: variation of pool water and air temp with each day of month at 9:00am

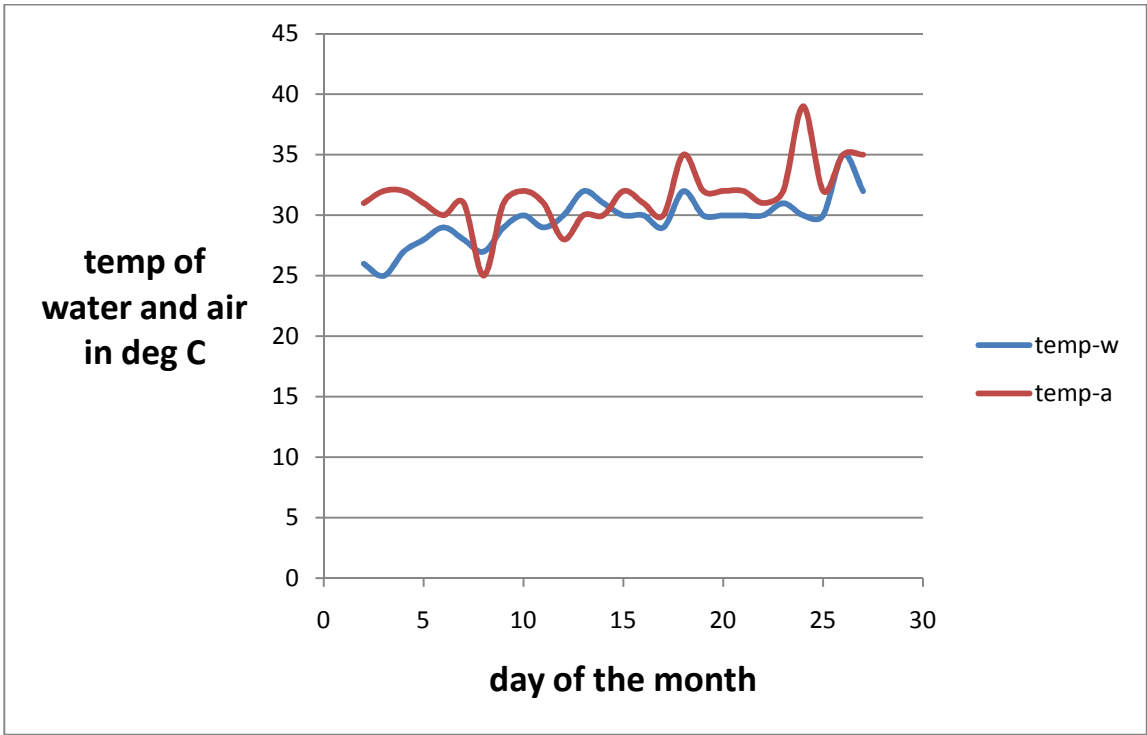

Figure 17: variation of pool water and air temp with each day of month at 12:00 noon.

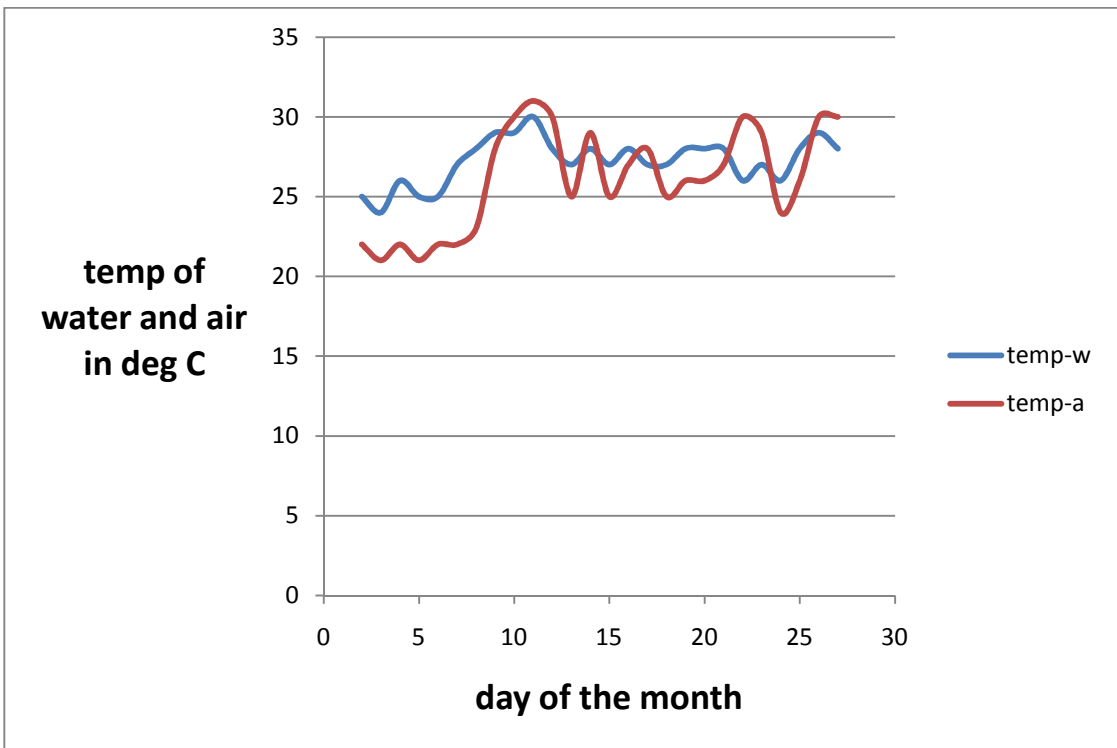

Figure 18: variation of pool water and air temp with each day of month at 4:00pm

6.2 DETERMINATION OF LOSSES FROM TEMPERATURE DATA

Using the temperature data recorded, losses were calculated for 12:00 noon. Evaporative, conductive, convective and radiative heat losses were calculated and percentage of each loss was plotted in a pie chart.

Table 6: losses calculation at 12:00 noon

DATE	Q _{eva} (KW)	Q _{cond} (KW)	Q _{conv} (KW)	Q _{rad} (KW)
2	126	3.135	20.5	29
3	176	4.389	28.6	41
4	132	3.135	20.5	32
5	80	1.8	12.26	19
6	27	0.627	4	6.4
7	80	1.8	12.26	19
8	43	1.2	8	9
9	55	1.254	8	13.5
10	58	1.254	8	14.8
11	55	1.254	8	13.5
12	106	2.508	16.34	27
13	55	1.254	8	14.9
14	26	0.627	4	7.08
15	58	1.254	8	14.9
16	29	0.627	4	7
17	27	0.627	4	6.4
18	97	1.881	12.26	28.19

19	50	1.254	8	12.18
20	58	1.254	8	14.9
21	58	1.254	8	14.9
22	50	1.254	8	12.18
23	275	0.627	4	7.8
24	305	5.643	36.8	93.8
25	58	1.254	8	14.9
26	2	0	0	0
27	97	1.881	12.26	28.19

PIE CHARTS TO SHOW % DISTRIBUTION OF EACH LOSS:

To show the % contribution of each loss, pie charts have been made for some days at 12:00noon time.

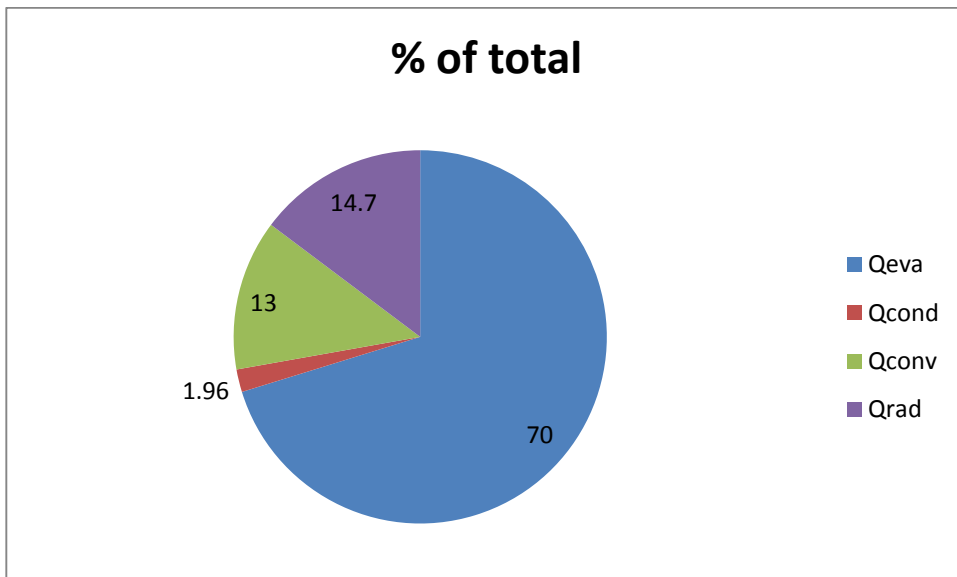

Figure19: % contribution of each loss on 8th November.

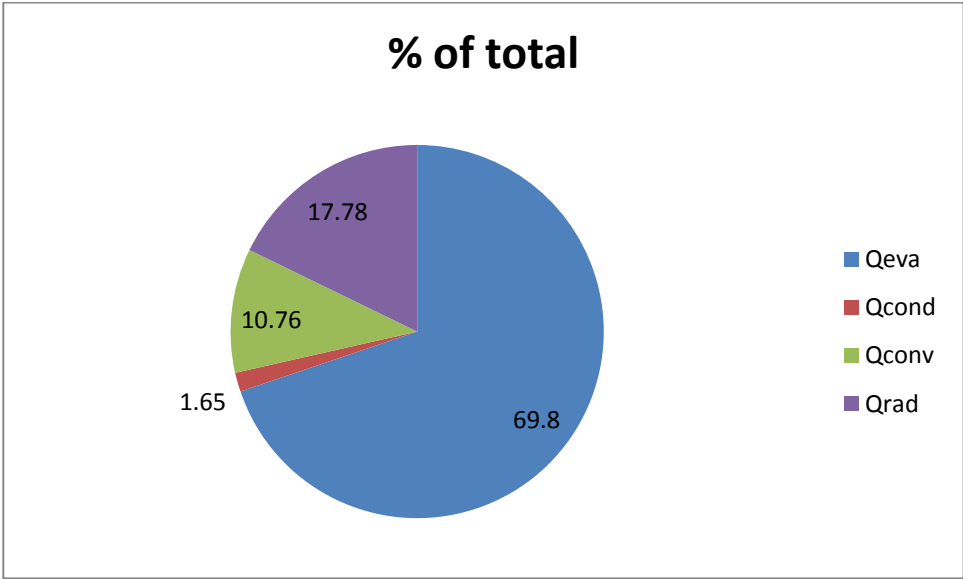

Figure 20: % contribution of each loss on 12th November.

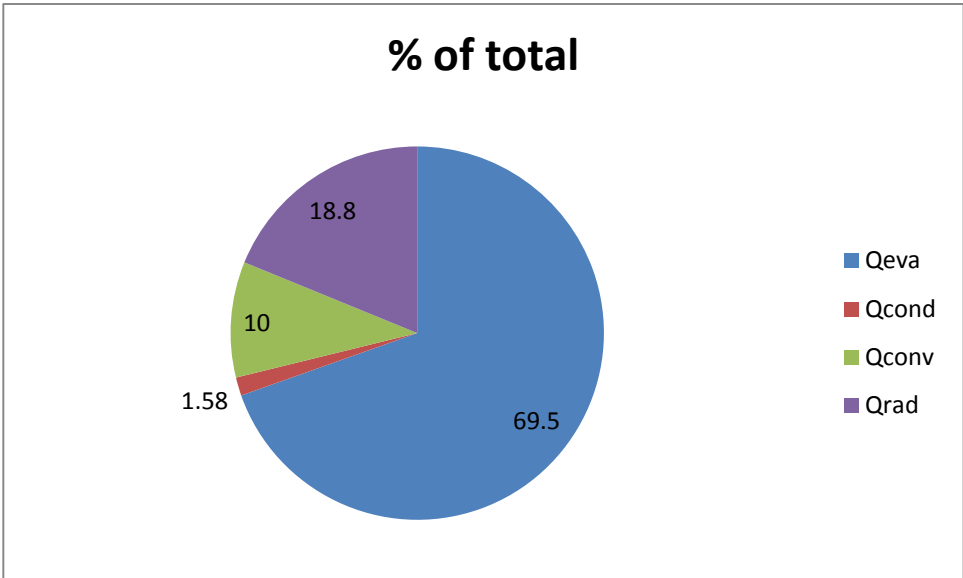

Figure 21: % contribution of each loss on 13th November.

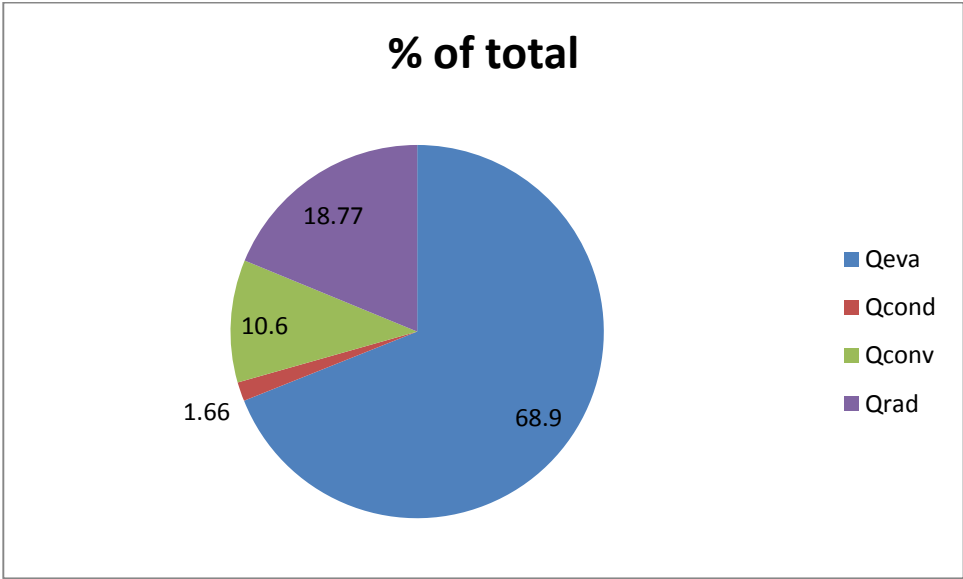

Figure 22: % contribution of each loss on 14th November.

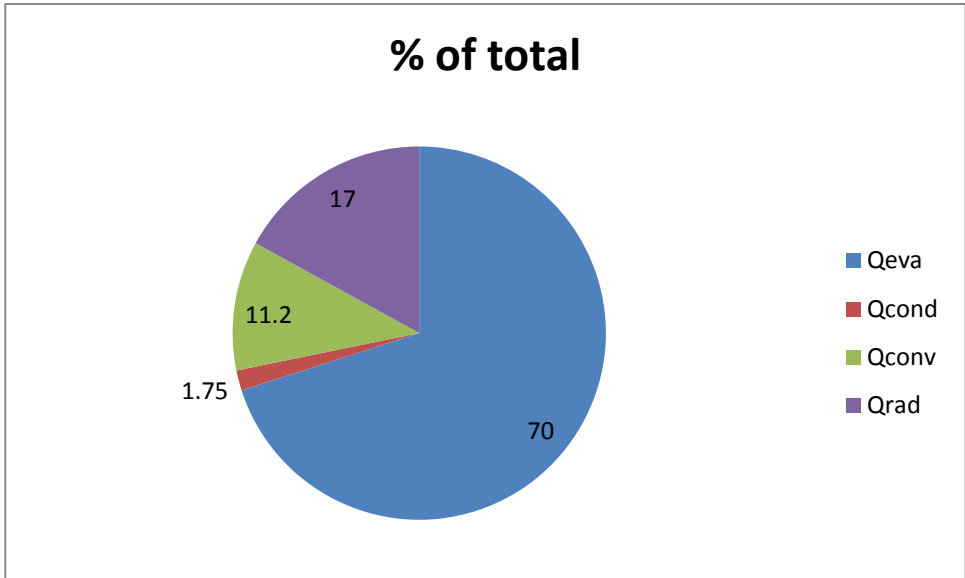

Figure 23: % contribution of each loss on 19th November.

Some observations from the heat loss data:

The evaporation heat loss was about 70 %.

The radiative heat loss varied between 14-18 %.

The convective heat loss varied between 10-13%.

The conductive heat loss was less than 2%.

The above observations are in full agreement with the data given in the literature. Hence heat loss profile has been calculated successfully for the swimming pool at NIT Rourkela.

6.3 ECONOMIC ANALYSIS OF HEAT PUMP BASED WATER HEATING SYSTEMS

Different heat pump models were considered to heat the pool water. Each KW rating model has two variants, one with low COP and the other with a high COP. Monthly operating costs have been calculated for each model and number of units required for each model to raise the temperature of pool water by 10 degree Celsius for 6 hours heating period have been estimated.

The table below shows the results:

Table 7 :cost analysis and no. Of unit required for each model

MODEL	KW RATING	COP	HEAT DELIVERED (KW)	MONTHLY OPERATING COST(Rs) FOR 1 UNIT	UNITS REQUIRED
AWHNHP10 N	12	4.17	50.04	5400	68
WWHCNHP10 D.S.	12	6.25	75	5400	46
AWHNHP12.5 N	13.5	4.63	62.505	6075	55
WWHCNHP12.5 D.S.	13.5	6.96	93.96	6075	37
AWHNHP25 N	26	4.75	123.5	11,700	28
WWHCNHP25 D.S.	26	7.15	185.9	11,700	19
AWHNHP50 N	52	4.75	247	23,400	14
WWHCNHP50 D.S.	52	7.6	395.2	23,400	9

Though the operating cost of a model with two different COP is same, the cost price and heat output will be different. For a same KW rating model, higher COP model will deliver more heat and it will be costlier than low COP model. The purchasing and installation cost of each model will be constant and their monthly operating cost will vary according to existing electricity charges, which vary from place to place and also on mode of electricity generated.

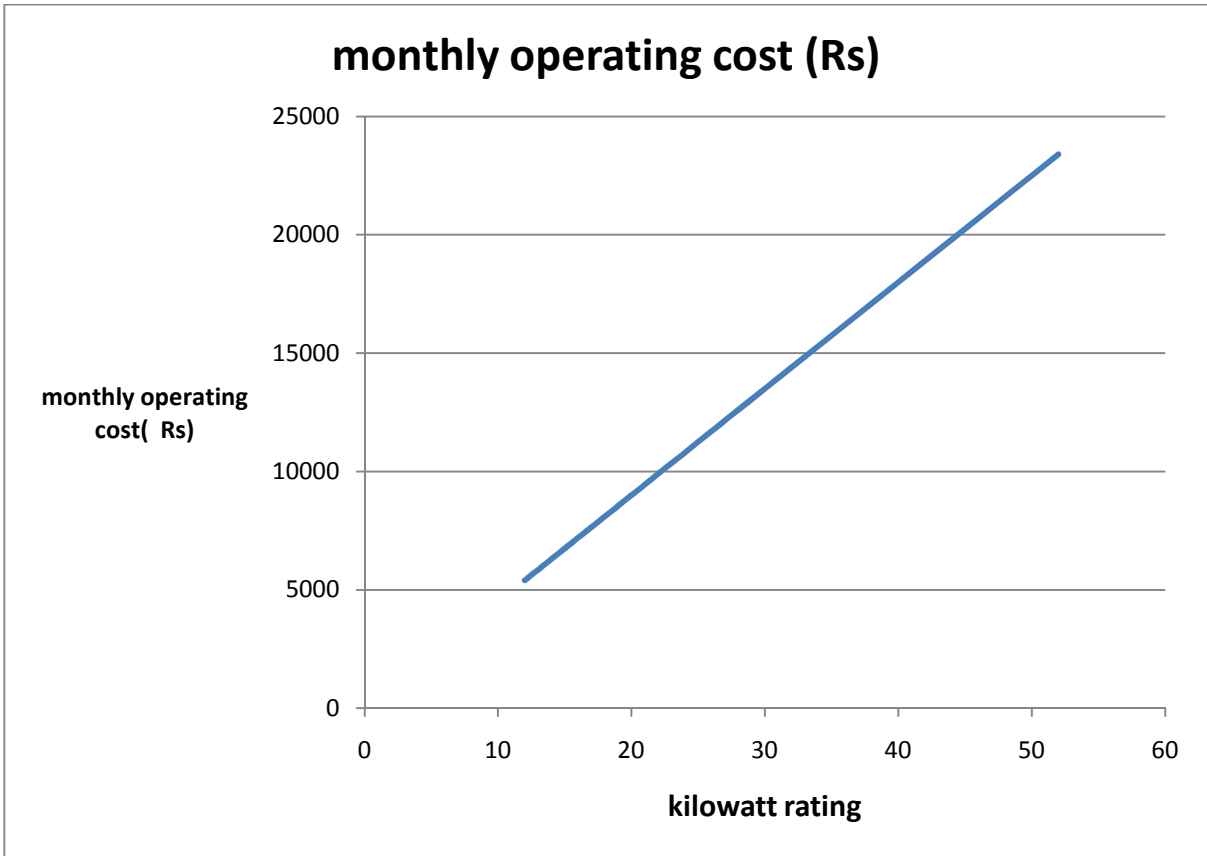

Figure 24: plot of KW rating Vs monthly operating cost.

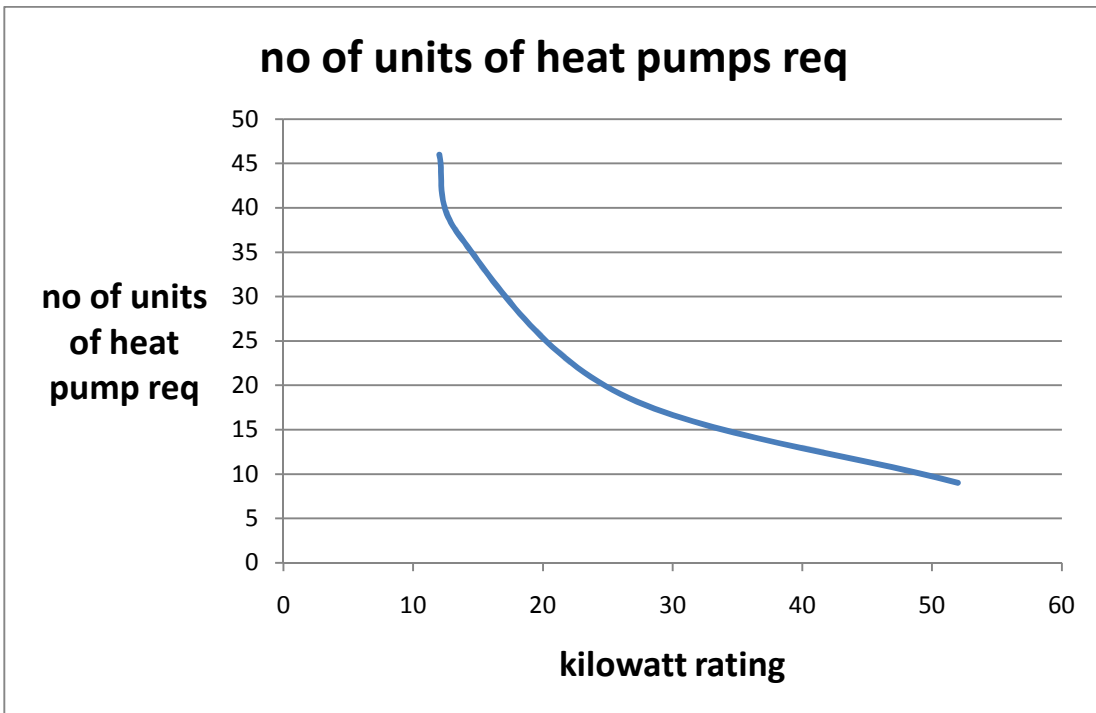

Figure 25: plot of KW rating Vs no. of units required.

As we can see from the plot, monthly operating cost increases linearly with increase in KW rating of the heat pump.

Now, total cost = fixed cost + operating cost

Here, fixed cost is equipment plus installation cost.

Therefore, for two models with same KW rating and different COP, the one having higher COP will have more total cost than the one with lower COP. We also see that as the KW rating increases, no. of units required of the model decreases. But also cost price of each model increases with increasing KW rating and COP.

6.4 ECONOMIC ANALYSIS OF NATURAL GAS HEATER BASED WATER HEATING SYSTEM

Cost analysis has been carried out for different rating and efficiency models of natural gas heaters. The details are listed below in the form of a table:

Table 8 :monthly operating costs and no. of units required for each model of gas heater

Model .no	Input power (KW)	Efficiency (%)	Heat delivered (output) in KW	Monthly operating costs for 1 unit (Rs)	No. of units required
1	55	80	43.95	8850	78
2	52	85	44.22	8400	77
3	26	85	22	4200	155
4	12	85	10.2	1935	334

We see that as the KW rating increases, no of units required decreases and monthly cost also increases. This is shown in the graph below:

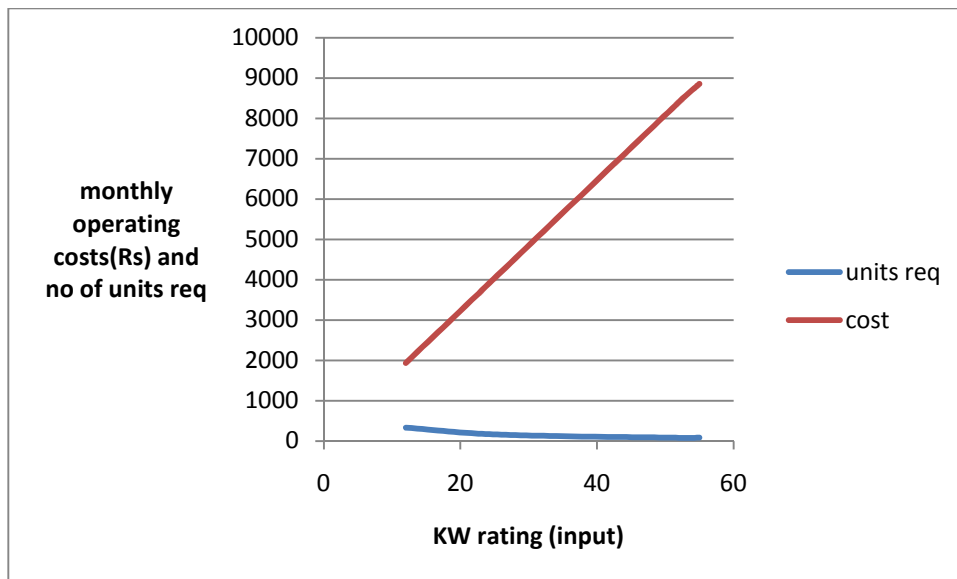

Figure 26 : KW rating Vs monthly operating costs and no. of units required.

6.5 COST COMPARISON BETWEEN HEAT PUMPS AND NATURAL GAS HEATERS

Heat pumps and natural gas heaters are both a viable option from efficiency point of view. But the final decision to choose will depend on which one is more economically viable. A comparison between heat pump and natural gas heaters has been done in terms of cost and no. of units required.

Table 9 : cost comparison between heat pumps and natural gas heaters.

KW rating (input power)	Monthly operating cost (Rs)	Monthly operating cost (Rs)	No of units required	No of units required	Annual operating cost (Rs) *10 ⁵	Annual operating cost (Rs) *10 ⁵
	Heat pump	NG heater	Heat pump	NG heater	Heat pump	NG heater
12	5400 (COP=4.17)	1935 (efficiency=0.8)	68	334	44	77.55
26	11700 (COP=4.75)	4200 (efficiency=0.8)	28	155	39.3	78.12
52	23400 (COP=7.6)	8400 (efficiency=0.8)	9	77	25.27	77.6

As we can see from the data, number of units required in case of natural gas heaters is too high. Even for high rating natural gas heaters, no. of units required is too large. It is very difficult to install so many heaters.

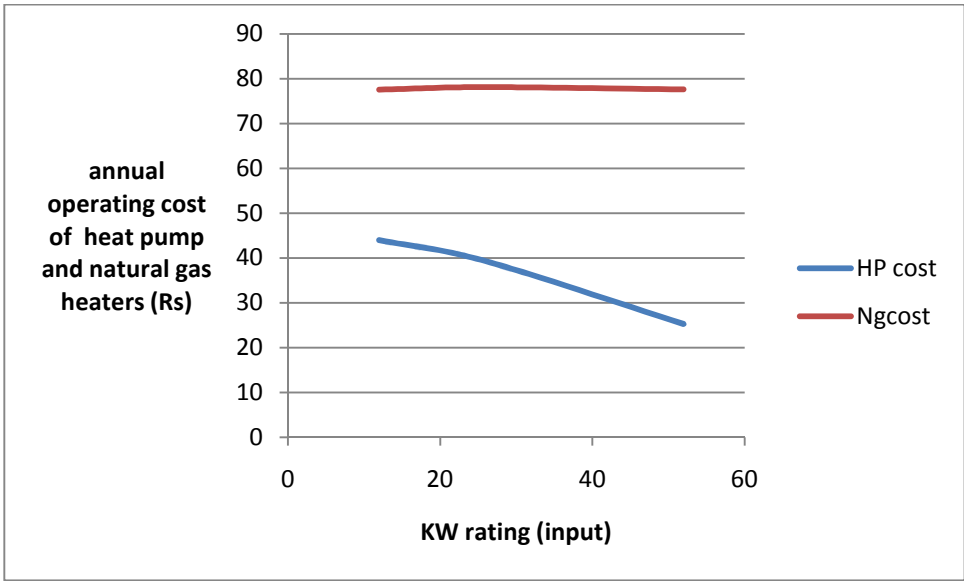

Figure 27 : cost comparison between heat pumps and natural gas heaters.

From the table we see that though the monthly operating cost of a single natural gas heater is less than a heat pump for the same rating, but since a large number of natural gas heaters is required, the annual operating cost of natural gas heaters shoot up as compared to heat pumps. The operating cost of natural gas heaters is 1.8-3 times more than heat pumps annually. Therefore economically, heat pumps are a better option than natural gas heaters.

6.6 DESIGNING OF WATER HEATING SYSTEM BASED ON SOLAR ENERGY

A design has been proposed to heat the pool water by using a solar heating system. A solar panel is made by coiling pipe on a wooden base. Inlet and outlet pipes from each solar panel are connected to respective main headers from where the pool water is distributed.

A schematic diagram of the solar panel is shown

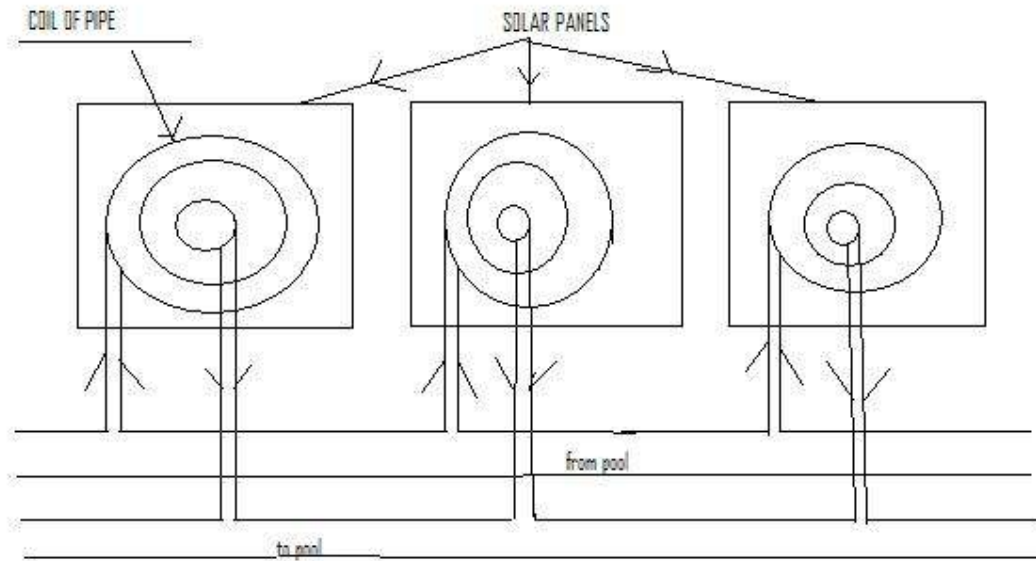

Figure 28: flow sheet showing the connections of the solar panel and its basic design.

This design can be used to raise 50% of the heat requirement. The other 50% can come from conventional heaters. In this way we can achieve a balanced system giving both credibility and economic viability to pool heating.

This system will reduce the operating cost of conventional heaters by half. Renewable source of energy is being utilized which will decrease the dependence on fossil fuels.

CHAPTER 7

CONCLUSIONS

CONCLUSIONS:

- Temperature variation of pool water and air above the pool at different times was recorded for the month of November. Graphs were plotted based on this data which showed the intersection of two temperature curves at least once a day.
- Based on the temperature data obtained, various losses associated with the pool were calculated and percentage of each loss with respect to the total loss was shown in form of pie charts.
- About 70% loss was evaporative, about 18% was radiative loss, convective loss was about 10% and conductive loss contributed less than 2%. This is in complete agreement with the literature data.
- Three heating systems based on different heating sources are proposed:
- Cost analysis of heat pump as heating source was done. Heat pumps are very efficient but they are very costly and are a threat to environment.
- Cost analysis of natural gas based heater was done. Though they are effective heaters, they are 2-3 times costlier than heat pumps and natural gas is a renewable source of energy, thus its use as a heating medium in swimming pool should be avoided.
- A system based on 50% solar energy and 50% conventional heaters is proposed. A design of solar panel to be used is provided. In this way, we make use of the abundant solar energy and also make the system efficient by incorporating conventional heaters. This system will prove cost effective in long run.

SCOPE FOR FUTURE WORK:

- For the whole winter season i.e., from October to February, temperature of the pool water, temperature of air above the pool, humidity and air velocity can be recorded. Using this data, mathematical equations and models can be developed for the swimming pools located in tropical climate like that of Rourkela.
- Experiment can be done on the proposed solar panel. By using no of panels and connecting them in series, one can see by using a given flow rate, how much temperature rise is possible. Based on the experimental results, power generated by each panel and size of each panel can be calculated. Number of panels required can be calculated and thus these panels can be fabricated for heating swimming pool water.
- A swimming pool cover can be installed over the pool to reduce the losses due to evaporation. This will reduce the heat requirement and will thereby reduce the cost of heating.

REFERENCES:

- [1] Brambley M.R. and Wells S.E. Energy conservation measures for indoor swimming pools, *Energy*, 8(6), 1983, pp. 403-418.
- [2] Technical manual. Swimming pool operation and maintenance, TM 5-662, 28 feb 1986, chapter 14-swimming pool heating.
- [3] Matuska T., Zmrhal V. and Metzger J. Detailed modelling of solar flat collectors with design tool kolektor 2.2, eleventh international IBPSA conference, Glasgow, Scotland, july 27-30, 2009.
- [4] Misra R.S. Evaluation of economic and thermal performance of closed loop solar hybrid air and water heating systems for Indian climates, *Energy Convers, Mgmt* Vol 34(5), 1993, pp. 363-372.
- [5] Alkhamis A.I. and Sherif S.A. Performance analysis of a solar assisted swimming pool heating system, *Energy*, Vol.17(12), 1992, pp.1165-1172.
- [6] Singh M., Tiwari G.N. and Yadav Y.P. Solar energy utilization for heating of indoor swimming pool, *Energy Convers, Mgmt* .Vol. 29(4), 1989, pp. 239-244.
- [7] Francey J.L.A, Golding. P and Clarke. R. Low cost solar heating of community pools using pool covers, *Solar Energy*, Vol 25, 1980, pp. 407-416.
- [8] Luminosu I. Flat plate solar collector technical constructive parameters determination by numerical calculation, considering the temperature criterion, *Romanian Reports in Physics*, Vol.56(1), 2004, pp. 13-19.
- [9] Francey J.L.A. and Golding P. The optical characteristics of swimming pool covers used for direct solar heating, *Solar Energy*, Vol 26, 1981, pp. 259-263.
- [10] Yadav Y.P. and Tiwari G.N. Analytical model of solar swimming pool : transient approach, *Energy Convers, Mgmt*. Vol 27(1), 1987, pp.49-54.
- [11] Haaf W., Luboschik U. and Tesche B. Solar swimming pool heating: description of a validated model, *Solar Energy*, Vol.53(1),1994, pp. 41-46.
- [12] Kayali .R. Economic analysis and comparison of two solar energy systems with domestic water heating systems, *Tr.J. of Physics*, Vol 22, 1998, pp. 489-496.

- [13] Kim Y., Han GY. and Seo T. An evaluation of thermal performance of CPC solar collector, International communications in heat and mass transfer, Vol35(4), 2008, pp.446-457.
- [14] Lee WS. and Kung CK. Optimization of heat pump system in indoor swimming pool using particle swarm algorithm, Applied thermal engineering, Vol.28(13),2008, pp.1647-1653.
- [15] Czarnecki J.T. Swimming pool heating by solar energy, CSIRO division of Mechanical Engineering, Technical Report, TR 19, 1978.
- [16] www.learnaboutpools.com
- [17] www.swimmingpoolsetc.com
- [18] www.jacksons-camping.co.uk
- [19] www.nrel.gov
- [20] www.swimmingpoolheaters.blogspot.com
- [21] www.coolace.com
- [22] www.solarsunrings.com
- [23] www.poolsinc.com
- [24] www.nationalheatpumps.com