

DESIGN AND SIMULATION OF DIFFERENT CONTROLLERS FOR SPEED CONTROL OF CHOPPER FED DC MOTOR

JYOTI PRAKASH RANA (109EE0299)

SUMAN JAIN (109EE0273)



**Department of Electrical Engineering
National Institute of Technology Rourkela**

DESIGN AND SIMULATION OF DIFFERENT CONTROLLERS FOR SPEED CONTROL OF CHOPPER FED DC MOTOR

*A Thesis submitted in partial fulfillment of the requirements for the degree of
Bachelor of Technology in “Electrical Engineering”*

By

JYOTI PRAKASH RANA(109EE0299)

SUMAN JAIN (109EE0273)

Under guidance of

Prof. K.B MOHANTY



Department of Electrical Engineering
National Institute of Technology
Rourkela-769008 (ODISHA)
May-2013



DEPARTMENT OF ELECTRICAL ENGINEERING
NATIONAL INSTITUTE OF TECHNOLOGY, ROURKELA
ODISHA, INDIA-769008

CERTIFICATE

This is to certify that the thesis entitled “**DESIGN AND SIMULATION OF DIFFERENT CONTROLLERS FOR SPEED CONTROL OF CHOPPER FED DC MOTOR**”, submitted by **Jyoti Prakash Rana (Roll. No. 109EE0299)**, **Suman Jain (Roll. No. 109EE0273)**, in partial fulfilment of the requirements for the award of **Bachelor of Technology in Electrical Engineering** during session 2009-2013 at National Institute of Technology, Rourkela. A bonafide record of research work carried out by them under my supervision and guidance.

The candidates have fulfilled all the prescribed requirements.

The Thesis which is based on candidates’ own work, have not submitted elsewhere for a degree/diploma.

In my opinion, the thesis is of standard required for the award of a bachelor of technology degree in Electrical Engineering.

Place: Rourkela

**Dept. of Electrical Engineering
National institute of Technology
Rourkela-769008**

**Prof. K.B Mohanty
Associate Professor**

ACKNOWLEDGEMENTS

We would like to articulate our deep gratitude to our project guide Prof. K B Mohanty who has always been source of motivation and firm support for carrying out the project. We would also like to convey our sincerest gratitude and indebtedness to all other faculty members and staff of Department of Electrical Engineering, NIT Rourkela, who showed their great efforts and guidance at required times without which it would have been very difficult to carry out our project work. Moreover, an assemblage of this nature could never have been attempted with our reference to the works of others whose details are mentioned in the references section at the last. We acknowledge our indebtedness to all of them. Furthermore, We would like to take the name of our parents and God who directly or indirectly encouraged and motivated us during this dissertation.

Jyoti Prakash Rana

Suman Jain

B.Tech (Electrical Engineering)

**Dedicated to
Almighty GOD**

ABSTRACT

This paper presents a comparative study of speed control of a separately excited DC motor by using different type of controllers. Speed of separately excited DC motor can be varied below and above the rated speed by various techniques. It can be varied above rated speed by field flux control and below rated speed by terminal voltage control .Conventional controllers are commonly being used to control the speed of the DC motors in various industrial applications. It's found to be simple, robust and highly effective when the load disturbance is small. But during high load or rapid variation of load, the fuzzy technique based controllers proves to be fast and reliable. Using chopper input voltage can be varied and thus speed can be varied. For better performance of the DC motor various kind of controller namely P-I, I-P, Fuzzy logic controller are used. Proportional-Integral type controller is used to eliminate the delay and provides fast control. However, the P-I controller has some disadvantages such as: sluggish response to a sudden load change, the high starting overshoots and sensitivity to controller gains. So, the relatively new Integral Proportional (I-P) controller is proposed to overcome the disadvantages of the P-I controller .After obtaining the model of separately excited DC motor, it is simulated using MATLAB (Simulink) environment. Then fuzzy logic controller has been designed and performance has been observed. Finally a comparative study is done between all the controllers.

CONTENTS

Abstract	i
Contents	ii
List of Figures	iv
List of Tables	v
Abbreviations and Acronyms	vi

CHAPTER 1

INTRODUCTION

1.1 Introduction	2
1.2 Different Methods of Speed Control of DC Motor	3
1.3 Some Terms and Definitions	3
1.4 Armature Resistance Control	4
1.5 Field Flux Control	4
1.6 Ward Leonard Speed Control	5

CHAPTER 2

CHOPPER

2.1 Principle of Chopper Operation	7
2.2 Control Method of Chopper	8
2.2.1 Time Ratio Control	9
2.2.2 Current Limit Control	9

CHAPTER-3

MODELING OF SEPARATELY EXCITED DC MOTOR AND SPEED CONTROL

3.1 Modeling of Separately Excited DC Motor	11
3.2 Types Of Controller	13

3.3 a Comparative Study of P-I And I-P Controller	13
3.3.1 P-I Controller	14
3.3.2 I-P Controller	18
3.3.3 Comparison of P-I And I-P Controller	20

CHAPTER-4

FUZZY LOGIC CONTROLLER

4.1 Introduction	23
4.2 Principle Element to a Fuzzy Logic Controller	24
4.2.1 Fuzzification	24
4.2.2 Rule Base and Interface Engine	24
4.2.3 Defuzzification	24
4.3 Membership Function	25
4.4 Fuzzy Rule Base for Speed Control of DC Motor	25
4.5 Membership Function	27
4.6 Comparison between P-I ,I-P and fuzzy Controller	31

CHAPTER-5

CONCLUSION

5.1 Discussion	33
References	34

LIST OF FIGURES

Fig. No	Name of the Figure	Page. No.
2.1	Chopper Circuit and Voltage, Current Wave Form	8
3.1	Separately Excited DC Motor Model	11
3.2	Block Model of Separately Excited DC Motor	12
3.3	P-I Controller Transfer Function Model	15
3.4	MATLAB/SIMULINK Model for P-I Controller	16
3.5	Speed Response with P-I Controller	17
3.6	Speed Error Response with P-I Controller	17
3.7	I-P Transfer Function Model	18
3.8	MATLAB/SIMULINK Model for I-P Controller	19
3.9	Speed Response with I-P Controller	19
3.10	Speed Error Response with I-P Controller	20
3.11	Speed Response with I-P & P-I Controller	20
4.1	Block diagram of fuzzy logic controller	23
4.2	Membership Function for 'e'	27
4.3	Membership Function for 'ce'	27
4.4	Rule Surface	28
4.5	Simulink Model of Fuzzy Logic	29
4.6	Speed Vs Time Response without Load Disturbance using Fuzzy Logic	30
4.7	Speed Error without Load Disturbance using Fuzzy Logic	30
4.8	Speed Vs Time Response with Load Disturbance at 6 sec using Fuzzy Logic	31

LIST OF TABLES

Table. No.	Name of the Table	Page. No.
3.1	Comparison between P-I and I-P Controller	21
4.1	Rule Matrix for Fuzzy Speed Control	26
4.2	Comparison between P-I, I-P and Fuzzy Controller	31

ABBREVIATIONS AND ACRONYMS

DC	-	Direct Current
AC	-	Alternating Current
SISO	-	Single Input Single Output
MOSFET	-	Metal Oxide Semiconductor Field effect Transistor
GTO	-	Gate Turn On
IGBT	-	Insulated Gate Bipolar Transistor
PID	-	Proportional Integral Differential
PI	-	Proportional Integral
IP	-	Integral Proportional
PWM	-	Pulse Width Modulation
Emf	-	Electro Motive Force
MG Set	-	Motor Generator Set
BJT	-	Bipolar Junction Transistor
TRC	-	Time Ratio Control
FLC	-	Fuzzy Logic Control
DOB	-	Degree Of Belongingness
MATLAB	-	Matrix LABoratory

CHAPTER 1

Introduction

1.1 INTRODUCTION:

High performance motor drives are very much essential for industrial application. Most of the industries demand variable speed operation of motor. As synchronous motor is a constant speed motor so it is used in industries which demands constant speed operation of motor. Speed of DC motor can be varied below and above the rated speed by terminal voltage control and field flux control respectively. So DC motor is used in many applications such as steel rolling mills, electric vehicles, electric trains, electric cranes and robotic manipulators require speed controller to perform its tasks smoothly. DC motors provide good control of speed for acceleration and deceleration. Speed controller of dc motors is carried out by means of voltage control in 1981 by Ward Leonard for the first time.

Because of their simplicity, reliability, and low cost DC drives have long been used in industrial applications. Compared to AC drives system DC drives are less complex .For low horsepower ratings DC drives are normally less expensive. DC motors have been used as adjustable speed machines since long and a wide range of options have evolved for this purpose. DC motors are capable of providing starting and accelerating torque 4 times the rated torque . DC motors have long been the primary means of electric traction. They are also being used for mobile equipment like quarry, golf carts, and mining applications. DC motors are portable and well fit to special applications, like industrial equipment and machineries that are not easily run from remote power sources.

DC motor is a SISO (Single Input and Single Output) system which has torque/speed characteristics compatible with most mechanical loads. This makes a DC motor controllable over a wide range of speeds by proper adjustment of the terminal voltage. The regulated voltage sources used for DC motor speed control have gained more importance after the introduction of thyristor as switching devices in power electronics .Then semiconductor components such as MOSFET, GTO and IGBT have been used as electric switching devices. As the theory of DC motor speed control is extendable to other types of motors as well, hence DC motors are always a good option for advanced control algorithm.

Speed control means intentional variation in speed by applying different techniques.

Natural change of speed due to load variation is not considered in speed control.

Speed of DC motor can be controlled by:

- i. Varying terminal voltage
- ii. Varying field flux

1.2 DIFFERENT METHODS FOR SPEED CONTROL OF DC MOTOR:

- i. Varying terminal voltage using Rheostatic method for low power DC motors.
- ii. Use of conventional PID controllers.
- iii. Neural Network Controllers.
- iv. Constant power motor field weakening controller based on load-adaptive multi- input multi-output linearization technique (for high speed regimes).
- v. Single phase uniform PWM AC-DC buck-boost converter with one switching device used for armature voltage control.

1.3 SOME TERMS AND DEFINITION:

- i. Base speed: The speed at which the motor runs at rated voltage and rated field current is called its base speed or rated speed. It is always available at the name plate of every motor.
- ii. Speed regulation: The difference between no load speed to full load speed expressed as the percentage of no load speed is called speed regulation.
- iii. Constant power mode: during constant power mode motor maintains constant output power over a given speed range. During constant power mode high torque is available at low speed and low torque is available at high speed. As power is directly proportional to product of speed and torque so here power remain constant .e.g: electric train, lift and hoist load
- iv. Constant torque mode: During constant torque mode load torque remain constant over a given speed range. e.g: fan motor

1.4 ARMATURE RESISTANCE CONTROL:

In armature resistance control speed is varied up to rated speed. Speed can't be greater than rated speed in this method. This is also called constant torque mode operation of DC motor. Before inserting external resistance

$$I_{a1}(S) = (V_a - E_b)/(R_a + L_a(S)) \quad (1)$$

But after inserting R_{ext} current becomes

$$I_{a2}(S) = (V_a - E_b)/(R_a + R_{ext} + L_a(S)) \quad (2)$$

Due to addition of external resistance armature current decreases from I_{a1} to I_{a2} . correspondingly torque decreases from T_{e1} to T_{e2} as torque is directly proportional to current. As torque decreases speed of motor decreases and hence back emf decreases,

and as
$$I_a(S) = (V_t - E_b)/(R_a + L_a(S)) \quad (3)$$

So due to decrease in back emf armature current again increases till it reaches previous one. So due to constant armature current and armature flux torque develop in the motor remain constant. Hence it is called constant torque mode.

1.5 FIELD FLUX CONTROL:

Voltage is the limiting factor for controlling speed more than rated speed due to insulation consideration. In field flux control speed above base speed is possible but speed below rated speed is not possible. During speed control by field flux control output power as well as input power increases. So efficiency remain same.

Field flux control of speed for getting more speed is limited due to

- I. commutation problem and parking in brush
- II. stability problem
- III. over heating of armature

1.6 WARD LEONARD SPEED CONTROL:

In Ward Leonard method of speed control of DC motor speed can be varied above and below rated speed. In this method separately excited DC motor is used. For controlling speed MG(motor-generator) set is used. A separately excited DC generator is used for variable DC source. 3 phase induction motor is used as prime over. Field winding of motor and generator are connected with DC bus via field rheostat. For up to rated speed field flux of DC generator is varied so variable terminal voltage is available at motor terminal .and then for above rated speed field flux of motor is varied accordingly.

But nowadays MG set is replaced by solid state switches. MG set convert AC to DC, it is replaced by diode rectifier or thyristor. Main advantages of these solid state devices are:

- I. losses are minimum
- II. maintenance free operation
- III. capital cost is low
- IV. size reduces nearly 30 times

CHAPTER 2

Chopper

2.1 PRINCIPLE OF CHOPPER OPERATION:

A chopper is a high speed on-off switch which converts fixed DC input voltage to a variable DC output voltage. A Chopper is considered as a DC equivalent of an AC transformer as they behave in an identical manner. Choppers are more efficient as they involve one stage conversion.

Choppers are now being used all over world for rapid transit systems. These are also used in marine hoist, trolley cars, mine haulers and forklift trucks. It is predicted that in future electric automobiles will be using choppers for their speed control and braking purpose. Chopper offer high efficiency smooth control, regeneration facility and faster response. The power semiconductor devices used for a chopper circuit can be force commutated thyristor, power BJT, IGBT, GTO and MOSFET based chopper are also used. These devices are represented by a switch. When the switch is being “off”, current does not flow. Current flows through the load when switch is “on”. When we switch it “on” it connect the load with source and when we put it at “off” it disconnect the load from source at a very fast speed .The on-state voltage drop of power semiconductor devices is nearly 0.5V to 2.5V across them. But for the sake of simplicity, the voltage drop across these devices is considered to be zero but practically it is not zero.

As mentioned above, a chopper is considered to be DC equivalent of AC transfer. Voltage can be step up or step down by varying the duty ratio of chopper as it is done by varying the turns ration in a transformer. from the figure we can see that during the period T_{on} , chopper is on and hence load voltage is equal to source voltage V_s and during the period T_{off} , chopper is off and hence load voltage is zero. In this way, a chopped dc voltage is produced at the load terminal .

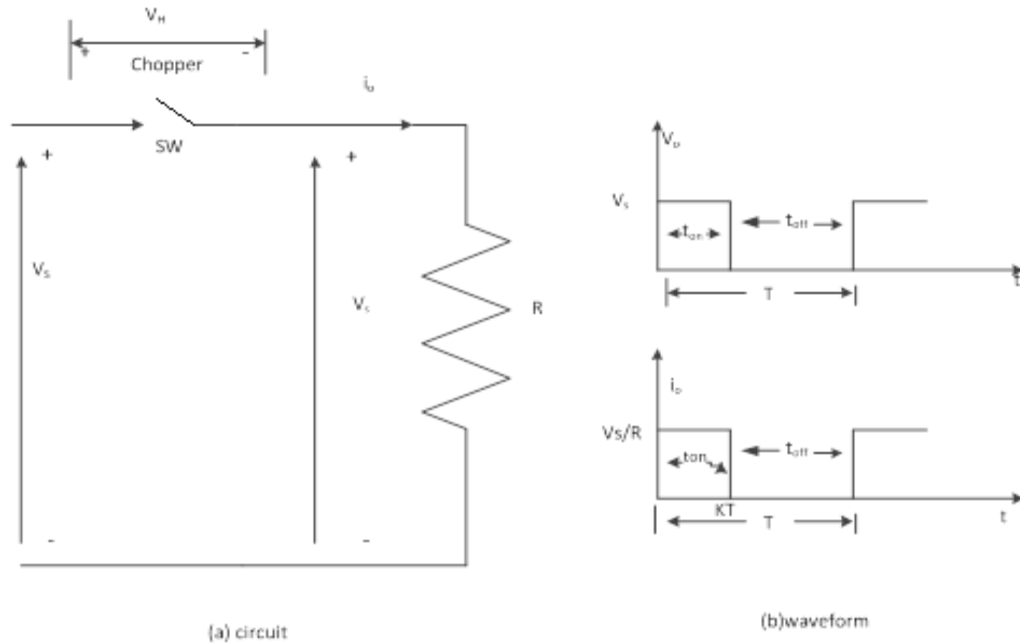

Figure 2.1: Chopper Circuit and Voltage and Current Waveform.

Average Voltage, $V_o = (T_{on} / (T_{on} + T_{off})) V_s$

$$V_o = (T_{on}/T) * V_s = \alpha V_s \quad (4)$$

Where T_{on} =on-time and T_{off} =off-time.

$T = T_{on} + T_{off}$ = Chopping period and $\alpha = T_{on}/T$.

Hence the voltage can be controlled by varying duty cycle α .

2.2 CONTROL METHODS:

The average value of output voltage V_o can be controlled through changing duty cycle by opening and closing the semiconductor switch periodically. Followings are the different control strategies for varying duty cycle :

1. Time ratio Control (TRC)

2. Current-Limit Control.

2.2.1 TIME RATIO CONTROL (TRC):

In this control scheme, time ratio T_{on}/T (duty ratio) is varied. This is done by two different ways called

i. CONSTANT FREQUENCY SYSTEM

In this scheme, on-time is varied but chopping frequency f is kept constant. This is also called pulse-width-modulation scheme as in this scheme we change the pulse with by changing the on time.

ii. VARIABLE FREQUENCY SYSTEM

In this technique, the chopping frequency f is varied and the on time or off time is remain constant. So duty ration is varied .

(1) on-time T_{on} is kept constant or

(2) off-time T_{off} is kept constant.

The method of controlling duty ratio so as to change the voltage level is also called Frequency-modulation scheme.

2.2.2 CURRENT- LIMIT CONTROL:

In this control method, turning on and off of chopper circuit is decided by the previous set value of load current. The set values are upper limit of load current and lower limit of load current that is maximum and minimum load current. When the load current reaches the upper limit, chopper is being switched off. When the load current falls below lower limit, the chopper is being switched on. Switching frequency of chopper can be controlled by varying the maximum and minimum level of load current.

CHAPTRE 3

Modelling of Separately Excited DC Motor and Speed Control

3.1 MODELLING OF SEPARATELY EXCITED DC MOTOR :

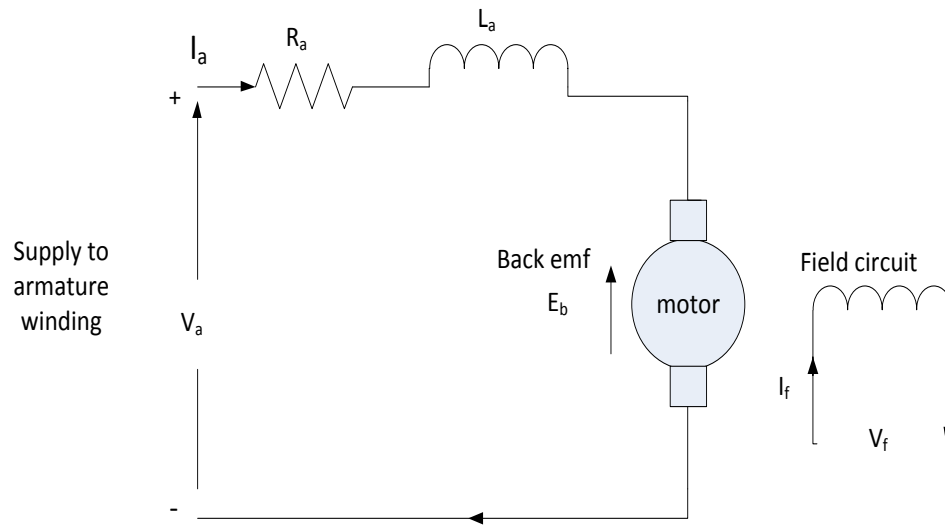

Figure 3.1: Separately Excited DC motor model.

The armature equation is shown below:

$$V_a = E_b + I_a R_a + L_a \left(\frac{dI_a}{dt} \right) \quad (5)$$

Where

V_a is the armature voltage in volts.

E_b is the motor back emf in volts.

I_a is the armature current in amperes.

R_a is the armature resistance in ohms.

L_a is the armature inductance in Henry.

Now the torque equation can be given by:

$$T_d = J \frac{d\omega}{dt} + B\omega + T_L \quad (6)$$

Where: T_L is load torque in Nm.

T_d is the torque developed in Nm.

J is moment of inertia in kg/m².

B is friction coefficient of the motor.

ω is angular velocity in rad/sec.

Taking Back EMF Constant as K_b and Electrical torque constant as K_T

Equation for back emf of motor can be written as :

$$E_b = K_b \omega \quad (7)$$

And also,

$$T_d = K_T I_a \quad (8)$$

From motor's basic armature equation, and taking Laplace Transform on both sides of the equation, we will get:

$$I_a(S) = (V_a - E_b)/(R_a + L_a S) \quad (9)$$

And from the Torque equation, we have

$$\omega(s) = (T_d - T_L)/JS+B \quad (10)$$

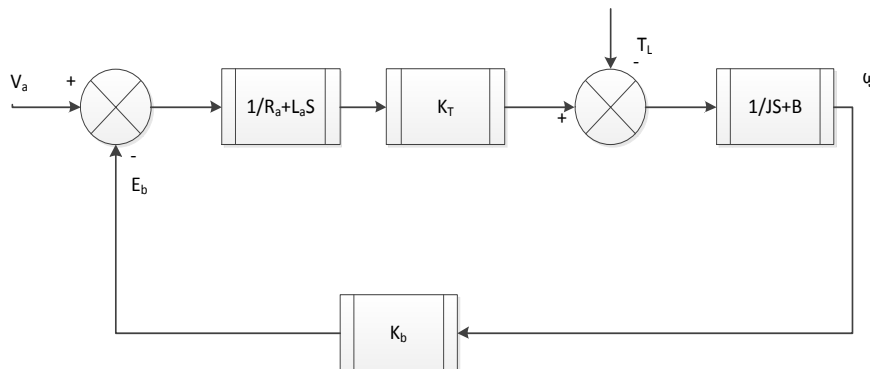

Figure 3.2: Block Model of Separately Excited DC Motor

Motor's parameters: The motor used in this experiment is separately excited DC motor, rating 2.5 hp at rated voltage of 220 V, and the motor's parameters are as follows:

Armature resistance (R_a) = 0.55 Ω

Back emf constant (K) = 0.55 V/rad/s

Mechanical inertia (J) = 0.0465 kg.m²

Friction coefficient (B) = 0.004 Nm/rad/s & Rated armature current (I_a) = 20 A

3.2 TYPES OF CONTROLLER:

- i. P Controller(proportional)
- ii. PI Controller (proportional plus integral) and IP Controller(integral plus proportional)
- iii. PID Controller (proportional-integral-derivative)
- iv. Fuzzy logic Controller

3.3 A COMPARATIVE STUDY OF P-I & I-P CONTROLLER:

A comparative study of PI & IP control scheme for a dc drive has been done here. The response of both P-I and I-P the controller for a change in speed reference and load torque is discussed. A one quadrant GTO chopper is used as power conditioning unit in the experimental set up using a separately excited dc motor. Most DC motor drives are operated as closed-loop speed control system.

A simple proportional gain in the speed loop may not be sufficient to provide a precise control on the speed of drives. This may results in a high overshoot and also an undesirable steady state error in speed. Therefore some kind of compensation technique has to be employed to improve the performance of the drive. The mostly used compensation method for DC motor drive is the proportional plus integral (P-I) control.

ADVANTAGES OF PI CONTROLLER:

- i. Due to presence of the integral term, steady state error in speed is zero, making the system quite accurate
- ii. It is not necessary to use such high gains as required in proportional gain controller.
- iii. The scheme has found to be quite robust and satisfactory.

DISADVANTAGES OF P-I CONTROLLER:

- i. If a very fast response is desired, the penalty paid is a higher overshoot in speed, which is not desirable.
- ii. The can be designed without any overshoot but the response to a load change becomes very slow.
- iii. A very high gain cannot be used, because that will resulting higher overshoots.

The IP controller tends to overcome some of the difficulties and limitations encountered with PI controller.

3.3.1 PROPORTIONAL-INTEGRAL (P-I)CONTROLLER:

The block diagram of the motor drive with the P-I controller has one outer speed loop and one inner current loop, as shown in Fig. 1. The speed error E_N between the reference speed N_R and the actual speed N of the motor is fed to the P-I controller, and the K_p and K_i are the proportional and integral gains of the P-I controller. The output of the P-I controller E_1 acts as a current reference command to the motor, C_1 is a simple proportional gain in the current loop and K_{CH} is the gain of the GTO thyristor chopper. For analysis the electrical time constant can be neglected, since it is very small as compared to mechanical time constant of the motor.

P-I TRANSFER FUNCTION MODEL:

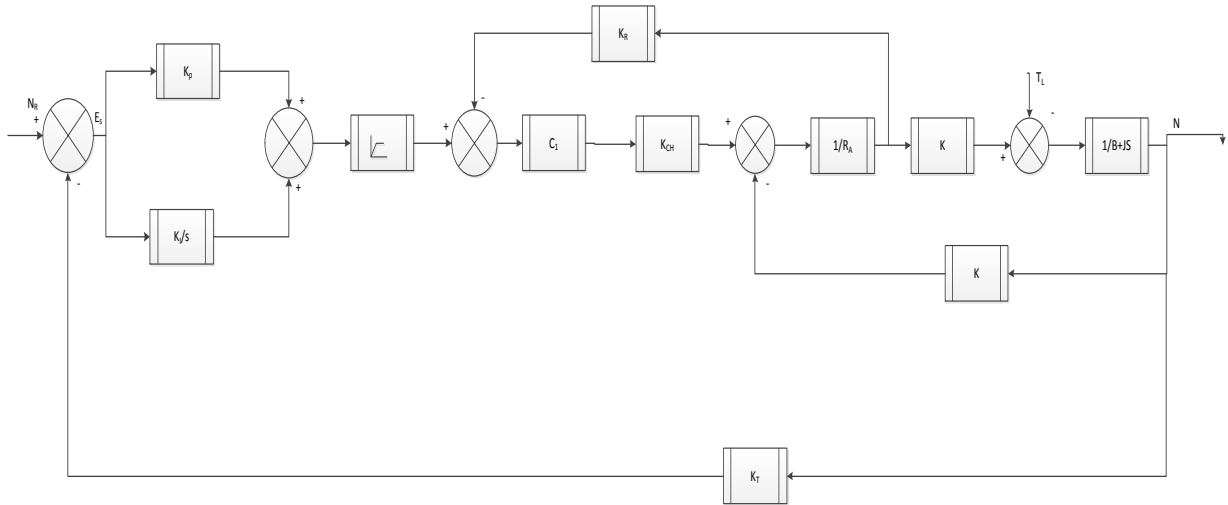

Figure 3.3: P-I Controller transfer function model

The P-I controller has the form

$$\frac{E_1(S)}{E_N(S)} = \frac{K_P S + K_I}{S} \quad (11)$$

This is a phase-lag type of controller with the pole at the origin and makes the steady-state error in speed zero. The transfer function between the output speed N and the reference speed NR is given by

$$\frac{N(s)}{N_R(s)} = \frac{AK_1 + AK_P S}{K_1 S^2 + K_2 S + K_3} \quad (12)$$

Where,

$$A = C_1 K_{CH} K \quad (13)$$

$$K_1 = R_A B T_M + C_1 K_{CH} B T_M \quad (14)$$

$$K_2 = R_A B + K^2 + C_1 K_{CH} B + AK_P \quad (15)$$

$$K_3 = AK_1 \quad (16)$$

$$T_M = \frac{J}{B} \quad (17)$$

K_i and K_p are controller gains, and R_A , B , T_M , etc. are motor and feedback constants. Equation(11) shows that the P-I controller introduces a zero and therefore a higher overshoot is expected for a step change in speed reference. This also prevents the use of high gains for K_p and K_i , an undesirable effect of the P-I controller.

The transfer function between the output speed N and load torque T_L is given by

$$\frac{N(S)}{T_L(S)} = -\frac{SK_4}{KS^2+K_2S+K_3} \quad (18)$$

Where
$$K_4 = R_A + K_R C_1 K_{CH} \quad (19)$$

The $-ve$ sign indicates that in the transient period there will be a drop in the speed for a step increase in load. However, in the steady state, there will not be any change in speed. This means that steady-state error in speed is zero, which is a good feature of P-I controller.

MATLAB/SIMULINK Model for P-I Controller:

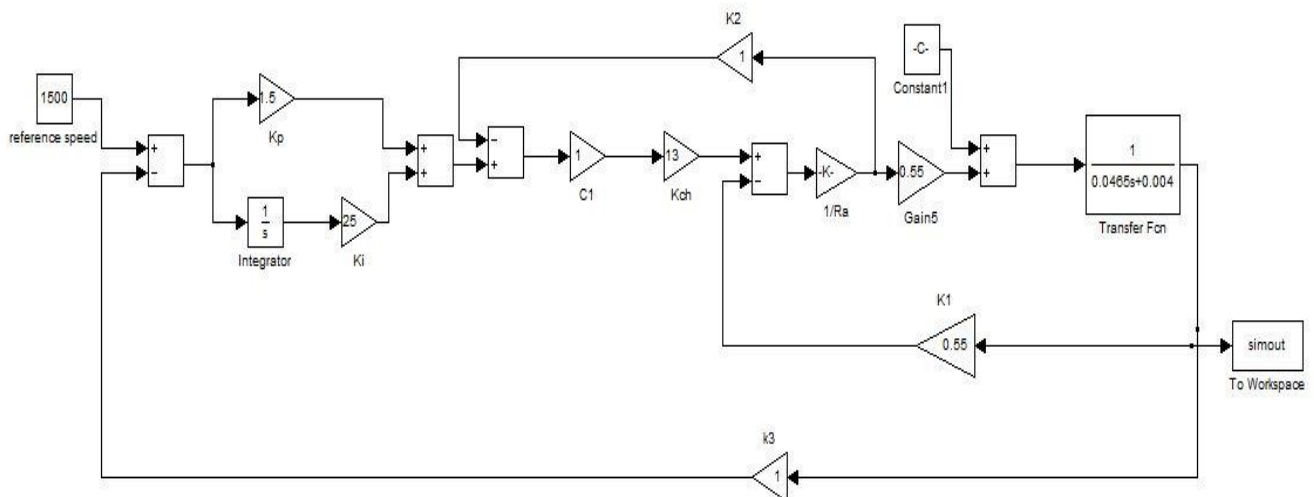

Figure.3.4: MATLAB/SIMULINK Model for P-I Controller

Simulation Results:

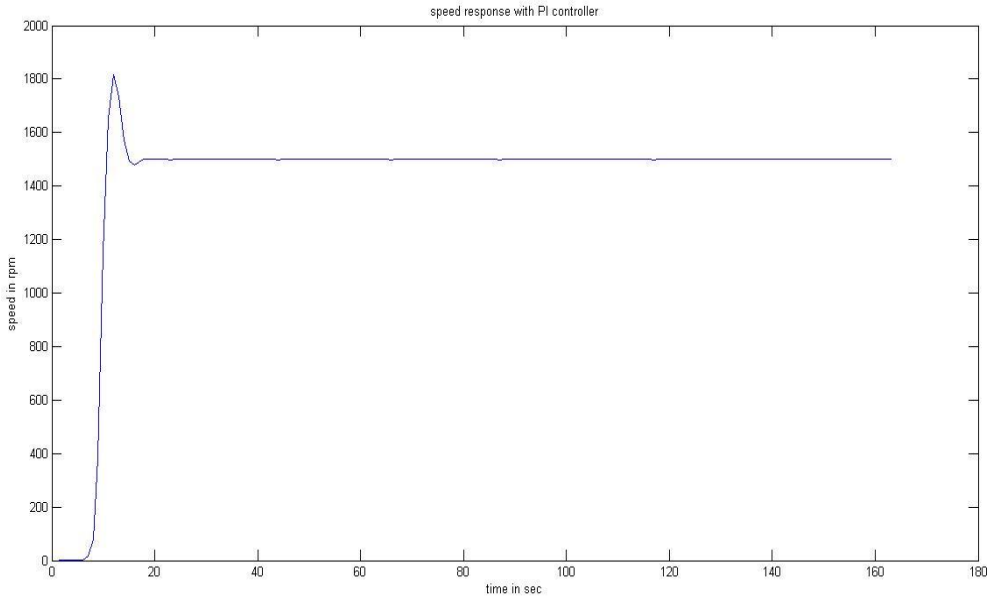

Figure 3.5: speed response with P-I controller

The P-I controller can be designed without much overshoot. However, the speed recovery from a load disturbance, in this case, deteriorates and becomes very slow, which is undesirable.

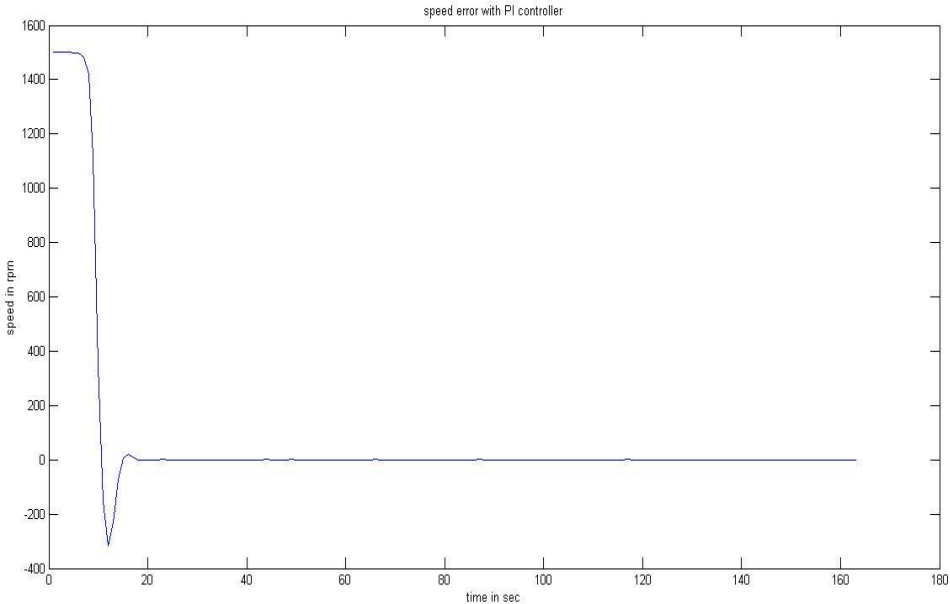

Figure 3.6: speed error with P-I controller

MATLAB/SIMULINK model of I-P controller:

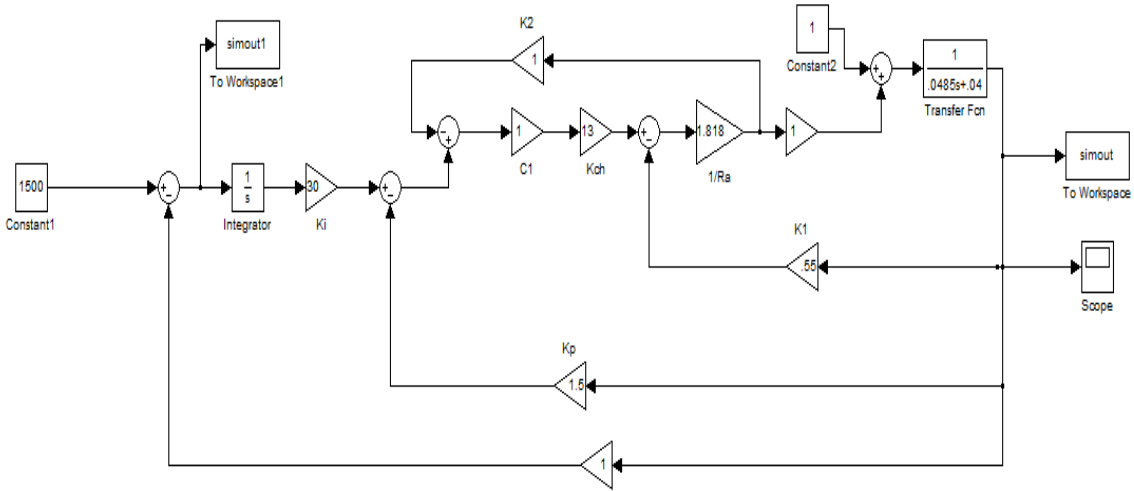

Fig.3.8:MATLAB/SIMULINK model of P-I controller

Simulation Results:

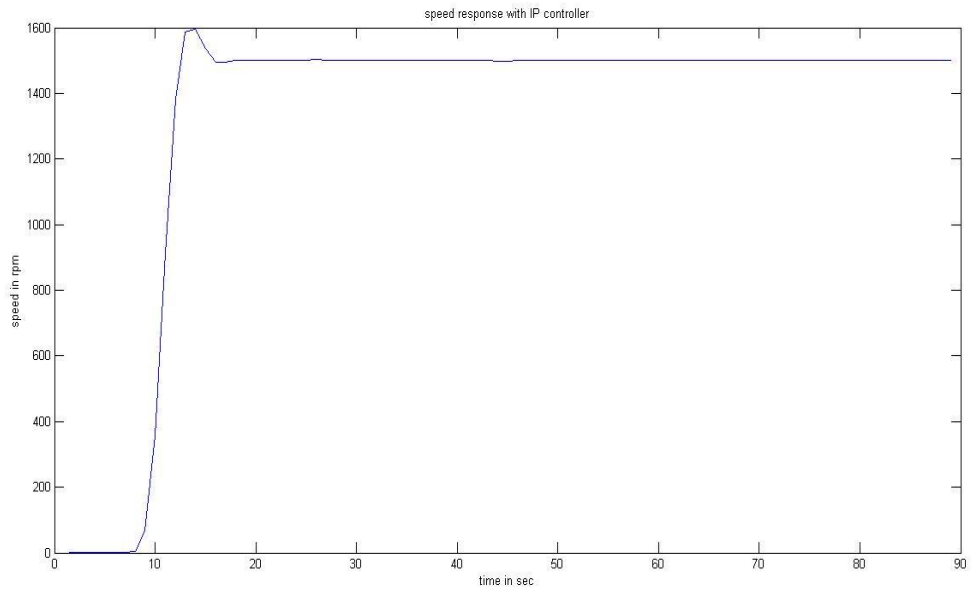

Figure 3.9: speed response with I-P controller

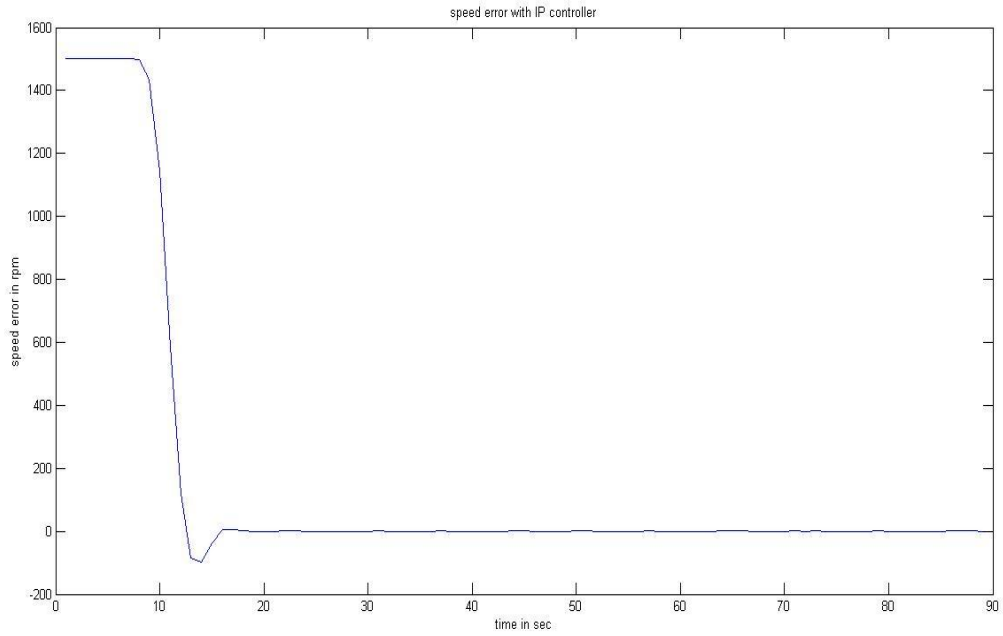

Figure 3.10: speed error with I-P controller

The response of the drive system is being obtained by setting the reference speed to 1500 rpm.

3.3.3 COMPARISON of P-I and I-P CONTROLLER:

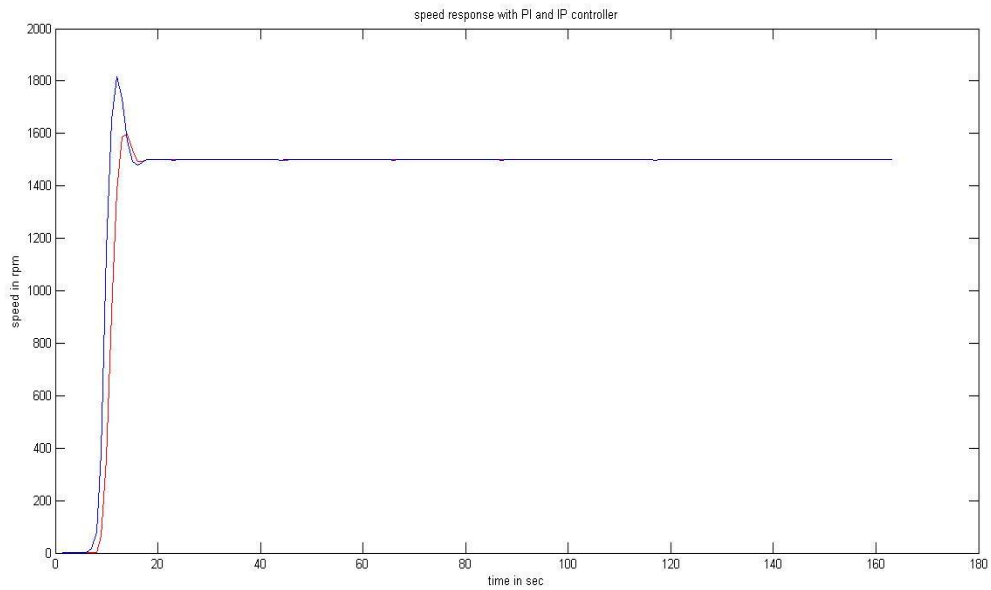

Figure 3.11: speed response with P-I & I-P controller

In case of the P-I controller an overshoot in speed can be seen , but the I-P scheme shows Negligible overshoot. It is clear from Figs.12 that the I-P controller performs slightly better than the P-I controller. The following table shows a comparison between PI and IP controller.

Table 3.1:comparison between PI and IP controller

	P-I Controller	I-P Controller
% Mp	20%	7.67%
Rise Time	10.4 sec	12 sec
Settling Time	18 sec	19 sec

CHAPTER 4

Fuzzy Logic Controller

4.1 INTRODUCTION:

Fuzzy logic control is one of the control algorithm based on a linguistic control strategy, which is being derived from expert knowledge into an automatic control strategy. Fuzzy logic control doesn't need any kind of difficult mathematical calculation like the others control system. While the others type of control system use difficult mathematical calculation to provide a model of the controlled plant, fuzzy uses only simple mathematical calculation to simulate the expert knowledge. Although it doesn't need any difficult mathematical calculation, but it gives good performance in a control system. Thus, it can be one of the best available answers today for a broad class of challenging controls problems.

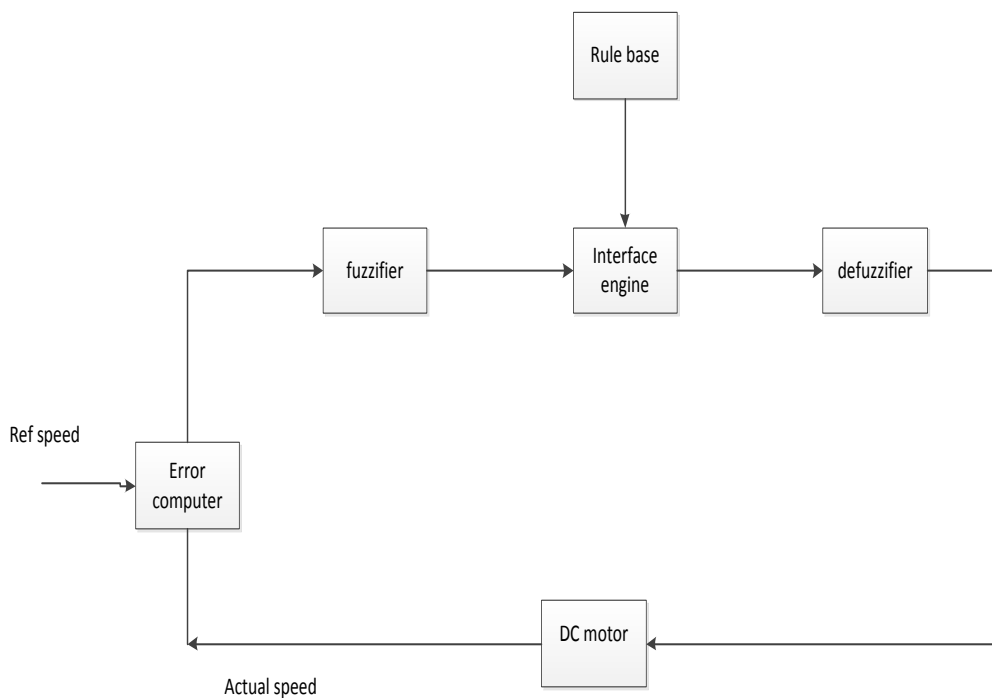

Figure 4.1: block diagram of fuzzy logic controller

Fuzzy Logic Controller (FLC) is an attractive choice when precise mathematical formulations are not possible. Other advantages are

- I. Allows imprecise/contradictory inputs. i.e it uses linguistic variables.
- II. Rule base or fuzzy sets can be easily modified.
- III. Relates input to output in linguistic terms, so easily understood.
- IV. Cheaper because they are easier to design and increased robustness than other non-linear controllers.

- V. Can achieve less overshoot and oscillation and doesn't require fast processors.
- VI. It requires less data storage in the form of membership functions and rules than conventional look up table for non-linear controllers.

4.2 PRINCIPAL ELEMENTS TO A FUZZY LOGIC CONTROLLER

- a. Fuzzification module (Fuzzifier)
- b. Rule base and Inference engine
- c. Defuzzification module (Defuzzifier)

4.2.1:FUZZIFICATION:

This process converts the measured inputs called crisp input, into the fuzzy linguistic values. The first step in designing a fuzzy controller is to decide which state variables represent the system dynamic performance must be taken as the input signal to the controller. Generally Fuzzy logic uses linguistic variables instead of any precise or numerical variables. The process of transforming a numerical variable (real number or crisp variables) into a linguistic variable (fuzzy number) is called Fuzzification. System variables, which are generally used as the fuzzy controller inputs includes states error, state error integral, state error derivative or etc. Here speed error and its derivative i.e change in speed error are chosen as the input signals.

4.2.2. RULE BASE AND INTERFACE ENGINE:

A collection of the expert control rules (knowledge) needed to achieve the control goal. This process will perform fuzzy logic operations and result the control action according to the fuzzy inputs.

4.2.3.DEFUZZIFICATION:

The reverse of Fuzzification is called Defuzzification. It is the transformation of a fuzzy quantity into a precise quantity, just like fuzzification is the conversion of a precise quantity to a fuzzy quantity. The use of Fuzzy Logic Controller (FLC) produces required output in a linguistic variable (fuzzy number).As per the real world requirements, the linguistic variables should to be transformed to a crisp output.

4.3 MEMBERSHIP FUNCTION:

The most important things in fuzzy logic control system designs are the process design of membership functions for inputs and outputs and design of fuzzy if-then rule knowledge base. A membership function is a graphical representation of the magnitude of participation of each input. There can be different memberships functions associated with each input and output response. In this study, we used the triangular membership function for input and output variables. The quality of control which can be achieved using fuzzy controller is determined by the number of membership function. With increase in the number of membership function, the quality of control improves. When the number of linguistic variables increases, the computational time and required memory also increases. Therefore, a compromise has to be considered between the quality of control and computational time to choose the number of linguistic variables. For the speed control of DC motor study, seven linguistic variables for each of the input and output variables are used to describe them.

4.4 FUZZY RULE BASE FOR SPEED CONTROL OF DC MOTOR:

The required algorithm for fuzzy speed control can be summarized as follows.

- A numerical example is included in each step for clarity of understanding the principle.
- The triangular membership functions for input variable speed error (e), change in speed error (ce) and control output (du) i.e. change in firing angle are shown in normalized units. The general considerations in the design of the controller are:
 - If both e and ce are zero, then maintain the present control settings i.e. $du=0$
 - If e is not zero but it is approaching to this value at a satisfactory rate, then maintain the present control Settings.
 - If e is increasing then change the control signal du depending on the magnitude and sign of e and ce to force e towards zero.
- ce and e are change in speed error and speed error respectively (normalized).
- du is change in firing angle (normalized).
- The Linguistic fuzzy sets are defined as below.
 - Z = zero
 - PS = Positive medium

- PM = Positive Big
- NS = Negative small
- NM = Negative medium
- NB = Negative Big

The table below shows the corresponding rule table for the fuzzy speed controller. The left column and the top row of the matrix indicates the fuzzy sets of the variable e and ce respectively and the membership function of the body of the matrix. There can be $7 \times 7 = 49$ possible rules in the matrix, where a typical rule reads as IF $e = PS$ and $ce = NM$ then $du = NS$.

Table 4.1: Rule matrix for fuzzy speed control

e ce	NB	NM	NS	Z	PS	PM	PB
NB	NB	NB	NB	NB	NM	NS	Z
NM	NB	NB	NB	NM	NS	Z	PS
NS	NB	NB	NM	NS	Z	PS	PM
Z	NB	NM	NS	Z	PS	PM	PB
PS	NM	NS	Z	PS	PM	PB	PB
PM	NS	Z	PS	PM	PB	PB	PB
PB	Z	PS	PM	PB	PB	PB	PB

4.5 MEMBERSHIP FUNCTIONS:

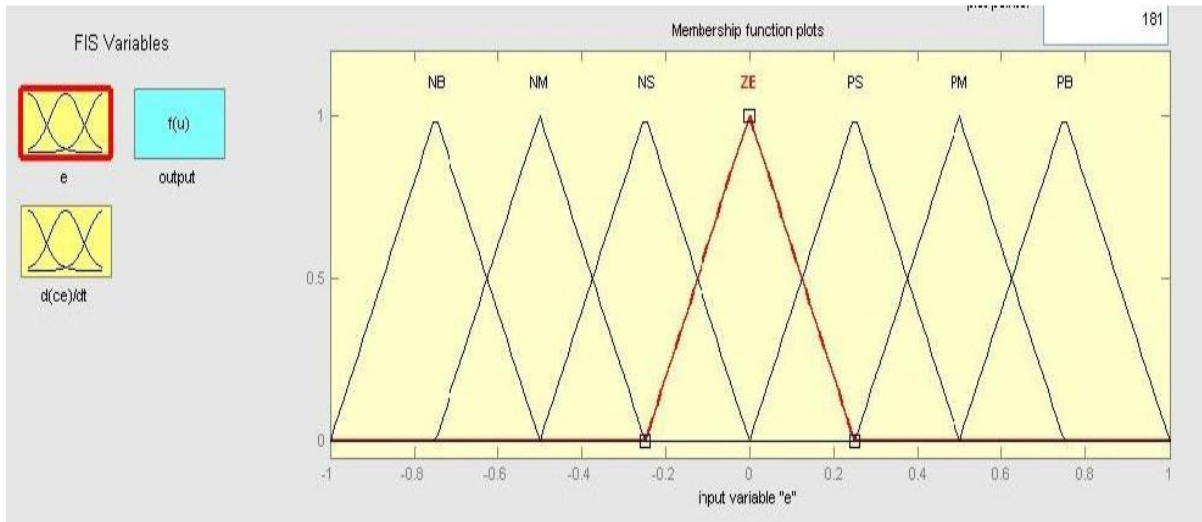

Figure 4.2: Membership function for 'e'

Membership function for ce :

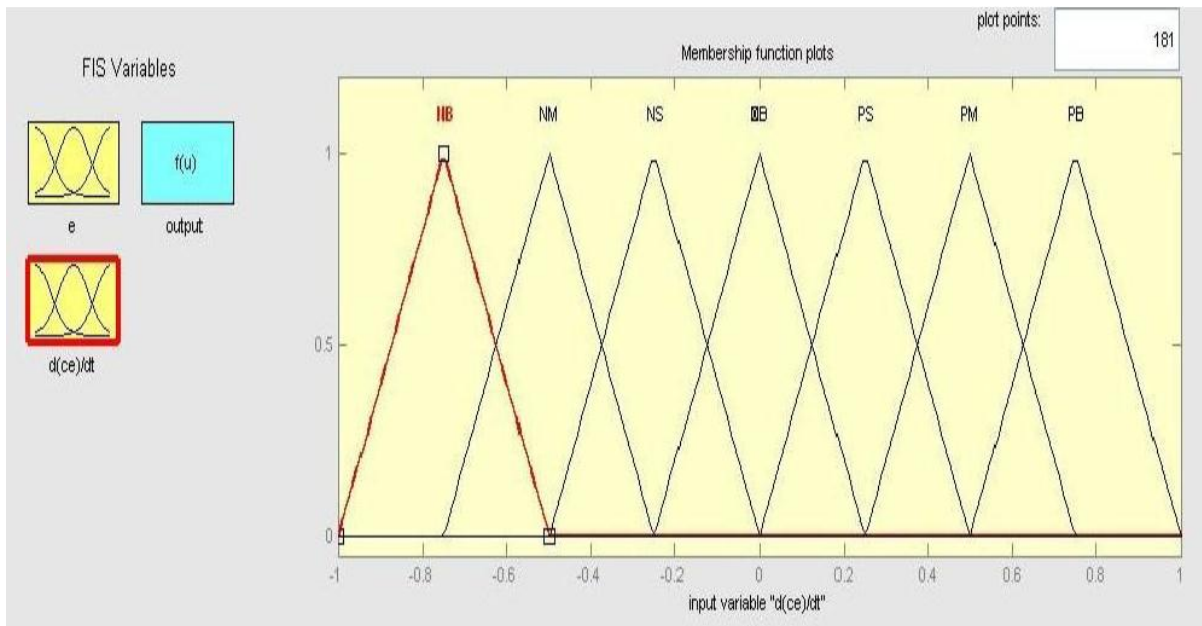

Figure 4.3: Membership function for 'ce'

Rule Surface:

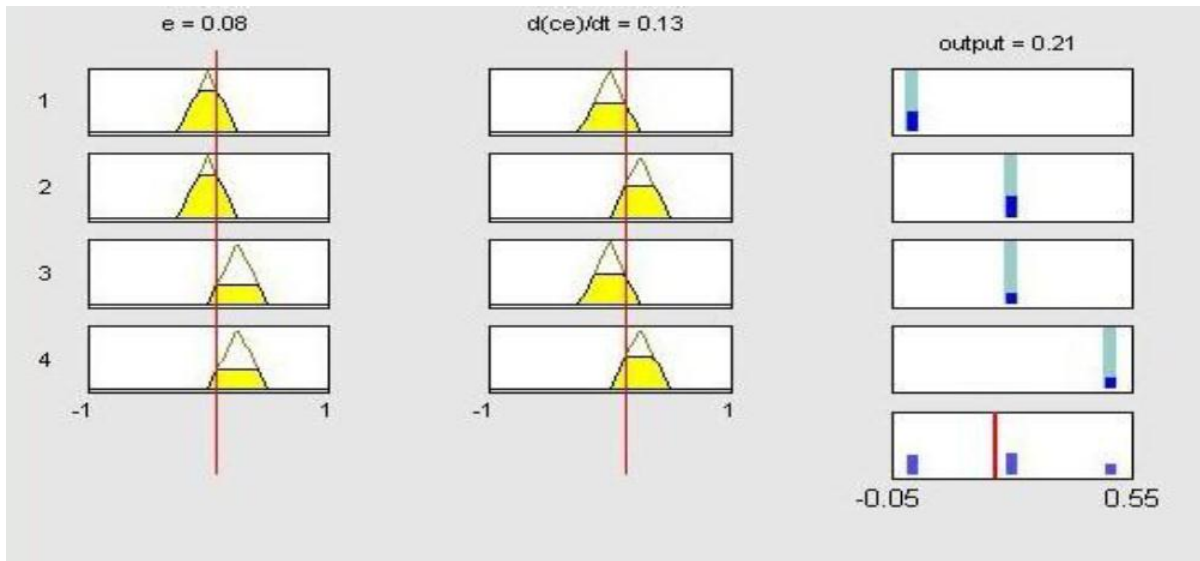

Figure 4.4: Rule surface

By calculating the DOB (degree of belongingness) of each rule using the AND or min operator, we have

$$DOB_1 = \min \{ \mu_Z(e), \mu_Z(ce) \} = \min \{ 0.6, 0.3 \} = 0.3$$

$$DOB_2 = \min \{ \mu_Z(e), \mu_{PS}(ce) \} = \min \{ 0.6, 0.7 \} = 0.6$$

$$DOB_3 = \min \{ \mu_{PS}(e), \mu_Z(ce) \} = \min \{ 0.4, 0.3 \} = 0.3$$

$$DOB_4 = \min \{ \mu_{PS}(e), \mu_{PS}(ce) \} = \min \{ 0.4, 0.7 \} = 0.4$$

Sample speed ωr^* and ωr

Compute error e and change in error ce

$$e(k) = \omega r^* - \omega r \quad (22)$$

$$ce(k) = e(k) - e(k-1) \quad (23)$$

From the figure $e=0.008$ and $ce=0.13$

Calculating the degree of membership of e and ce for the relevant fuzzy sets

$$\mu_Z(e) = 0.6 \text{ and } \mu_{PS}(e) = 0.4$$

$\mu_Z(ce)=0.3$ and $\mu_{PS}(ce) =0.7$

Retrieve the amount of correction du_i ($i=1,2,3,4$) corresponding to each rule in the table

$Du_1=0$ for Z corresponding to $DOB_1=0.3$

$Du_2=0.25$ for PS corresponding to $DOB_2=0.6$

$Du_3=0.3$ for PS corresponding to $DOB_3=0.3$

$Du_4=0.4$ for PM corresponding to $DOB_4=0.4$

By calculating the crisp du by weighted average defuzzification method ,we have

$$du = \frac{0.3 * 0.6 + 0.6 * 0.25 + 0.3 * 0.25 + 0.4 * 0.5}{0.21} = 0.21$$

Simulink Model:

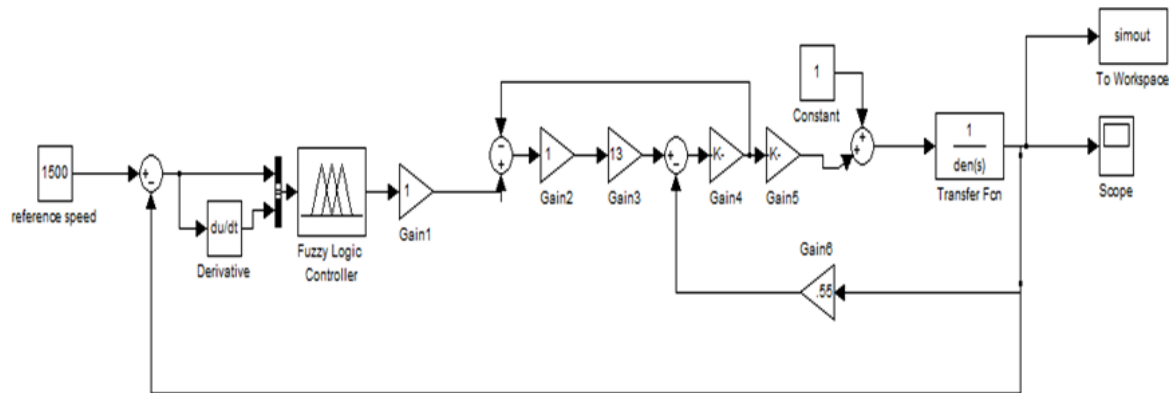

Figure 4.5: MATLAB/SIMULINK model of fuzzy controller

Simulation Results:

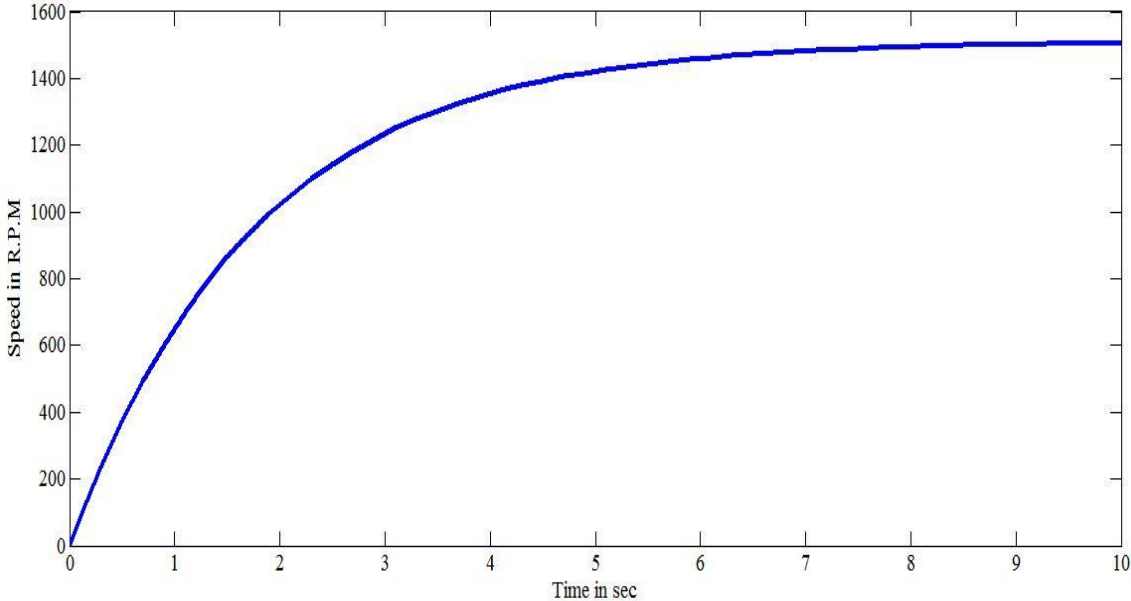

Figure 4.6: Speed Vs Time response without load using fuzzy logic

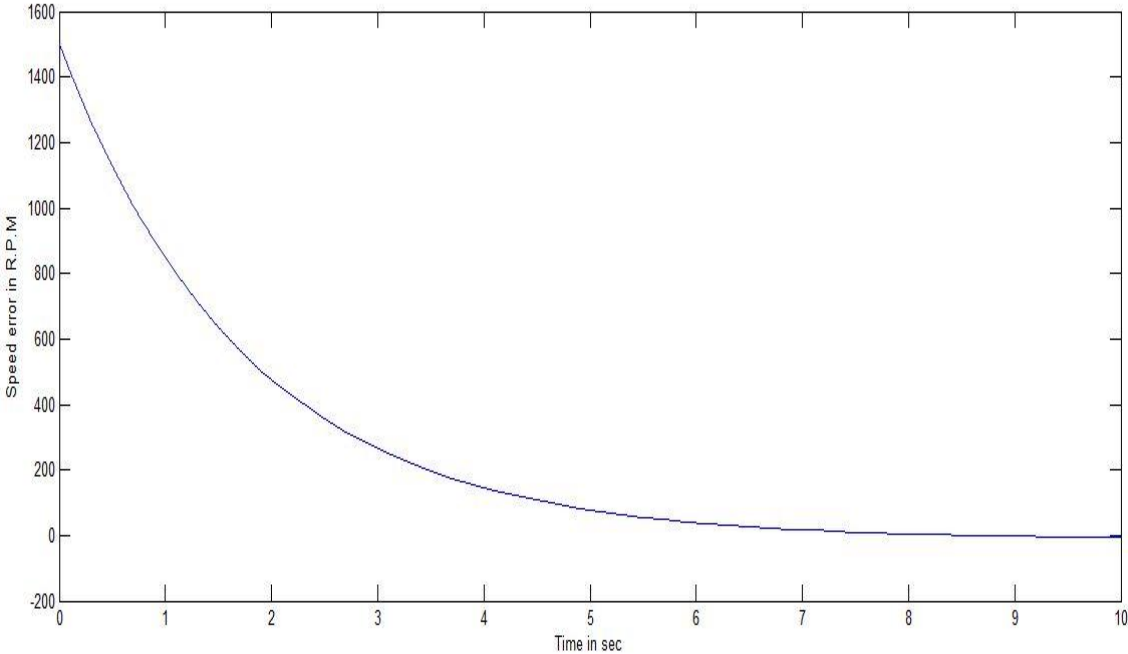

Figure 4.7: Speed error without load using fuzzy logic

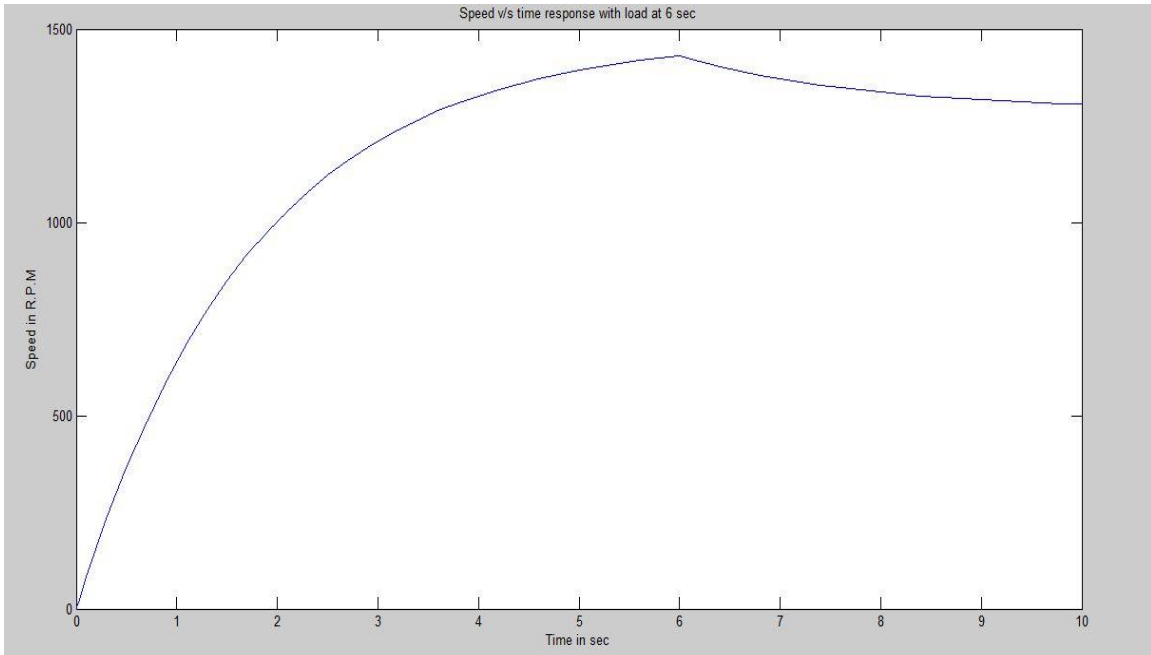

Figure 4.8: Speed vs Time response with load at time 6 sec using fuzzy logic.

4.6 Comparison Between P-I, I-P and Fuzzy Controller

Table 4.2: Comparison between P-I, I-P and Fuzzy controller

	P-I Controller	I-P Controller	Fuzzy Logic Controller
% Mp	20%	7.67%	0%
Rise Time	10.4 sec	12 sec	3.9 sec
Settling Time	18 sec	19 sec	4.5 sec

The performance of fuzzy controllers is compared by setting the reference speed to 1500 rpm from the initial condition. The results are shown in Figs. The performance of fuzzy controller is also tested by applying a large step change in load at time 6 sec. The system response for the above case is shown in Figs. In fuzzy control system we have smooth control with less overshoot and no oscillations than P-I and I-P controllers. It is observed that I-P controller provides more advantages over the traditional P-I controller such as limiting the overshoot in speed, thus the overshoot in starting current can be reduced.

CHAPTER 5

CONCLUSION

5.1 DISCUSSIONS:

The background of DC Motor is studied. The study of Characteristics of separately excited DC motor is done. The steady state operation and its various torque-current, torque-speeds characteristics of DC motor are studied. First a comparison has been done between the performance of P-I and I-P controller for dc motor control by setting the reference speed to 1500 rpm. The response is shown in Figs.12. It is clear from Figs.12 that the I-P controller performs slightly better than the P-I controller. We have studied basic definition and terminology of fuzzy logic with the help of Matlab and Wikipedia and some other websites. Due to simple formulas and computational efficiency, both triangular membership functions has been used to design fuzzy industrial controllers especially in real-time implementation. The speed of a separately excited DC Motor has been successfully controlled by using fuzzy logic controller technique. The performance of fuzzy controller is compared by setting the reference speed to 1500 rpm from the initial condition. The performance of fuzzy controller is also tested by applying a large step change in the load disturbance at time 6 sec. It has been found that fuzzy logic controller performs in a better way than the other conventional controllers with less overshoot and no oscillations. Graph for the speed response of separately excited DC Motor using fuzzy logic controller is compare with graph for the speed response of separately excited DC Motor without fuzzy logic controller.

REFERENCES:

- [1] M. I. Jahmeerbacus, M. K. Oolun, C. Bhurtun and K. M. S. Soyjaudah, "Speed-Sensor less Control of converter-fed Dc Motor", *In Africon.IEEE'99*, pp.453-456, 1999.
- [2] J. Nie, and T.H. Lee, (1997). Self-organizing rule-base control of multivariable nonlinear servomechanisms, *Fuzzy set and systems* 91: 285-304.
- [3] D.A. Likens and S.B. Hasnain. "Self-organizing Adaptive Fuzzy Controller." *Fuzzzy set and systems*, Vol. 80,1996, pp. 295-313.
- [4] G .K Dubey, *Fundamentals of Electrical Drives*. New Delhi, Narosa Publishing House, 2009.
- [5] Li-Xim Wang. *A Course in Fuzzy System and Control*. Prentice-Hall International, Inc. 1997.
- [6] E. H. Mamdani "Applications of Fuzzy Algorithm for simple Dynamic Plant." *Proceeding IEEE.*, Vol.121, No.12, 1974. pp. 1585-1588.
- [7] P.K. Nandam, and P.C. Sen, "A comparative study of proportional integral(P-I) and integral-proportional (I-P) controllers for dc motor drives," *Int. Jour. of Control*, Vol. 44, pp. 283-297, 1986.
- [8] Gilberto C.D. Sousa, and Bimal K. Bose, "A fuzzy set theory based control of phase-controlled converter dc machine drive", *IEEE Trans. Industry Applications*, Vol. 30, No.1, pp. 34-43, 1994.
- [9] Zadeh, L. A. et al. 1996 *Fuzzy Sets, Fuzzy Logic, Fuzzy Systems*, World Scientific Press, ISBN 9810224214.
- [10] Yodyium Tipsuwan and Mo-Yuen Chow, "Fuzzy Logic microcontroller implementation for DC motor speed control", *IEEE Transactions on Power Electronics*, Vol.11, No.3, June 1999, pp 1271-1276.
- [11] V.S.C. Raviraj and P.C. Sen, "Comparative Study of Proportional- Integral, Sliding Mode, and Fuzzy Logic Controllers for Power Converters", *IEEE Trans. on Industry Application*, vol.33, no. 2, Mar/Apr 1997 pp.518- 524.

- [12] Chinnaiyan V. Kumar, Jerome Joritha, Karpagam, J. S.Sheikh Mohammed, Design and Implementation of High Power DC-DC converter and speed control of dc motor using TMS 320F240DSP, Proceedings of India International Conference on Power Electronics, 2006.
- [13] B.K Bose., Power electronics and motor drives recent technology advances, Proceedings of the IEEE International Symposium on Industrial Electronics, IEEE, 2002, pp 22-25.
- [14] Saffet Ayasun, Gultekin Karbeyaz, DC motor speed control methods using MATLAB/SIMULINK and their integration into undergraduate courses, 2008.
- [15] Chuen Chien Lee, “Fuzzy logic in control systems: Fuzzy logic controller- part I”, IEEE trans. on system, man and cybernetics vol 20, No. 2, mar/ apr 1990.
- [16] The Math works Inc.,MATLAB/Simpower System demos/ Chppper-fed DC motor Drive.