

# **Load Flow Analysis of Unbalanced Radial Distribution Systems**

**Biswajit Naik(110EE0211)  
Nikhil Mudgal (110EE0210)  
Somanath Behera(110EE0190)**

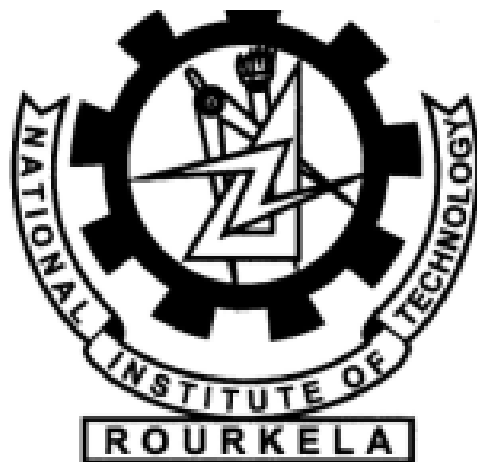

**Department of Electrical Engineering  
National Institute of Technology  
Rourkela  
2014**

# **Load Flow Analysis of Unbalanced Radial Distribution Systems**

*A Thesis submitted in partial fulfillment of the requirements for the degree of  
Bachelor of Technology  
In  
Electrical Engineering*

***By***

***Biswajit Naik  
Nikhil Mudgal  
Somanath Behera***

**Under the Supervision of**

**Prof. S. Ganguly**



**NATIONAL INSTITUTE OF TECHNOLOGY, ROURKELA**

**राष्ट्रीय प्रौद्योगिकी संस्थान, राउरकेरा**

**PIN-769008**

**ODISHA, INDIA**

*Dedicated To*

*Shree Jagannath*

*&*

*My beloved Parents*



DEPARTMENT OF ELECTRICAL

NATIONAL INSTITUTE OF TECHNOLOGY, ROURKELA- 769 008  
ODISHA, INDIA

---

# CERTIFICATE

---

This is to certify that the thesis report titled “***Load Flow Analysis of Unbalanced Distributed System***”, submitted to the National Institute of Technology, Rourkela by **Mr. Biswajit Naik, Nikhil Mudgal, Somanath Behera** for the award of **Bachelor of Technology** in Electrical Engineering, is a bonafide record of research work carried out by him under my supervision and guidance.

The candidate has fulfilled all the prescribed requirements.

The thesis report which is based on candidate’s own work, has not submitted elsewhere for a degree/diploma.

In my opinion, the draft report is of standard required for the award of a **Bachelor of Technology** in Electrical Engineering.

**Supervisor**

Department of Electrical Engineering  
National Institute of Technology  
Rourkela – 769 008 (ODISHA)

## ACKNOWLEDGEMENT

This work was carried out at the Department of Electrical Engineering, National Institute of Technology, Rourkela, Orissa, under the supervision of Prof. S. Ganguly.

We would like to express our sincerest gratitude to Prof. S. Ganguly for his guidance and support throughout my work. Without him we will never be able to complete our work with this ease. He was very patient to hear our problems that we were facing during the project work and finding the solutions. We are very much thankful to him for giving his valuable time for us.

Our special thanks to all our friends who did give their time for MATLAB Coding and providing us good company. And we would like to thank our friends who helped us in completing our thesis in time.

We thank God for giving us the chance to pursue our academic goals and a wonderful, complete life full of amazing people.

Finally, hearty thanks to our family member for their sacrifice that encouraged us to proceed with the work.

Biswajit Naik  
Nikhil Mudgal  
Somanath Behera

## **ABSTRACT**

**A thru tactic for unbalanced three-phase distribution load flow solutions is presented in this work. The distinctive topological characteristics of distribution networks have been fully exploited to make the direct solution possible. For unbalanced distribution system backward sweep is used for calculation of branch current and forward sweep is used for bus voltage. Due to the distinctive solution techniques of the approached method, the time-consuming Lower and Upper decomposition and forward or backward substitution of the Jacobian matrix or Y admittance matrix required in the traditional load flow methods are no longer necessary. Therefore, the approached method is robust and time efficient. Test results demonstrate the validity of the approached method. The approach shows excessive prospective to be used in distribution automation applications.**

# TABLE OF CONTENTS

ACKNOWLEDGEMENT	5
ABSTRACT	6
LIST OF FIGURES	8
LIST OF TABLES	8
CHAPTER 1	9
INTRODUCTION	9
1.1 Introduction	10
CHAPTER 2	13
Unbalanced Radial Distribution System	13
2.1 Unbalanced Radial Distribution System	14
CHAPTER 3	16
Forward-backward sweep load	16
3.1 Forward-Backward Sweep Load Flow Method	17
3.2 Backward Sweep	18
3.3 Forward Sweep	19
3.4 Forward Backward Sweep Method Algorithm	20
3.5 Flow-chart of unbalanced radial distribution load flow	21
CHAPTER 4	22
RESULTS AND DISCUSSIONS	22
19 BUS SYSTEM	24
08 BUS SYSTEM	25
CONCLUSION	27
REFERENCES	28
APPENDIX	29
5.1 Datasheet of 19 bus unbalanced radial distribution system	29
5.2 Datasheet of 8 bus unbalanced radial distribution system	32

## LIST OF FIGURES

<b>Title</b>	<b>Page No</b>
<b>Figure2.1</b> Three phase line section model	14
<b>Figure3.1.</b> Three bus power system network	17
<b>Figure3.2</b> Three phase line section	18
<b>Figure3.3.</b> Flow chart Algorithm	20

## LIST OF TABLES

<b>List of Tables</b>	<b>Page No</b>
<b>Table 3.1:</b> Classification of buses.	17
<b>Table 4.1:</b> Bus Voltage and angle in radian of 19 bus URDS.	25
<b>Table 4.2:</b> Total power and total line loss of 19 bus URDS in KVA.	25
<b>Table 4.3:</b> Bus Voltage and angle in radian of 8 bus URDS.	26
<b>Table 4.4:</b> Total power and total line loss of 8 bus URDS in KVA.	26



# **CHAPTER 1**

## **INTRODUCTION**

## 1.1 Introduction

Load flow analysis is a best as well as an elementary tool to study the power system engineering. Network optimization, state estimation, switching, Var. planning, operational use and planning of existing system to supply the future demand; load analysis serves the purpose. Development of new technologies and superiority of digital world like micro-controllers, thyristors etc. bring revolution in this field. Today we have lots of methods to study the load flow analysis like Newton Raphson Method, Gauss-siedel Method, Fast decoupled method, but those methods are great match for Transmission system. But unlike transmission system, distribution system has well-known different characteristics; some of them are as shown below:-

- Radial or weakly meshed structure;
- High R/X ratios of the feeders;
- Multi-phase and unbalanced operation;
- Unbalanced distributed load;
- Exceedingly large number of branches and nodes;
- Comprehensive resistance and reactance values.

Hence there is a requirement of an efficient and robust technique to handle the deal. the traditional load flow methods used in transmission systems; fail to meet the requirements in both performance and robustness aspects in the distribution system applications because of above mentioned features. Precisely, the assumptions necessary for the simplifications used in the standard fast-decoupled Newton method [1] often losses it's validity in distribution systems. Thus, a novel load flow algorithm for distribution systems is desired. All of the characteristics mentioned before must be considered, to qualify for a good distribution load flow algorithm.

There are lots of algorithms specifically designed for distribution systems have been suggested in the literature [2]. Most of these methods are derived from transmission networks and based on general meshed topology. Among those methods; Gauss implicit Z-matrix method is highly fashionable but when it comes to the distribution network, this method does not clearly exploit the radial and weakly meshed network structure of distribution systems and, therefore, a solution of a set of equations whose size is

proportional to the number of buses is required. Several other techniques, such as the 3- $\phi$  fast decoupled power flow algorithm [3], the Newton-Raphson method and phase decoupled method [4] etc., have also been anticipated. Another direct approach, which utilizes two matrices developed from the topological characteristics of the distribution system, is proposed in this paper work.

But, the dominance of the backward and forward sweep method(BFSM); over other solution techniques as it is fast for solving the load flow of radial distribution systems and effective; makes it more valuable. The ill-conditioned nature arising due to high R/X ratios of the feeders are taken care of by The “BFSM”, which eradicate the need of Fast decoupled Newton Method and Gauss Method. This techniques model the distribution network as a tree with the slack bus as the root. The backward sweep predominantly sums bus current to finally evaluate the branch current. And the forward sweep is used to calculate voltage drop, which provide updates to the voltage profile constructed from the current estimation of the flows. Ladder Network Theory have proposed by Kersting and Mendive and Kersting[4] to slove unbalanced radial distribution system. To solve un-balanced radial distribution networks by Backward Forward Sweep (BFS) Method; Thukaram et al. have proposed a three phase power flow algorithm. Ranjan et al. [5] have used Power addition based BFS method to solve un-balanced radial distribution grids.

Recent research presented some new ideas which requires different data format or some data manipulations to calculate the special topological appearances of distribution systems. Another technique; known as compensation-based technique to solve distribution load flow problems, is mentioned in [6]. Branch power flow rather than branch currents were later used in the improved version and presented.

Deep assessment and advance techniques which focuses on modeling of the un-balanced loads and isolated generators, was proposed in [7]. In [8], the “layer-lateral” based data format is presented while solving the feeder lateral based model. In compensation based technique; the new records have to be build and maintained; in addition to that, there is no scientific association between the system control variables and system status can be found. Thus, application of compensation-based algorithm becomes difficult.

The algorithm presented in this paper is a “decent but fundamental” procedure. The only input data of this algorithm is the line data and load data. From where we calculate the branch current by using bus current and finally evaluate the voltage profile of different buses. The goal of proposed thesis is developing an algorithm which can explain the unbalanced distribution load flow directly, also consider the mutual impedance if the system is either two phase or three phase. The time-consuming Lower-Upper decomposition and the Jacobian-matrix or the Y-admittance matrix [9], required in the traditional Newton Raphson and Gauss implicit Z matrix algorithms, are eradicated by this scheme and are not necessary in the new development. The proposed system is robust and effective and can work on any number of bus systems. The test results are shown in the end on different-different system which establish the validity as well as feasibility of the approached method.

## **CHAPTER 2**

### **UNBALANCED RADIAL DISTRIBUTION SYSTEM**

## 2.1 Unbalanced Radial Distribution System

Load flow study of Unbalanced Radial Distribution System is of a great matter of deal, since due to unbalancing of either 3-phase or 2-phase system the effect of mutual impedance term will arise when we compute the voltage of a bus. Unbalance system not only leads to mutual impedance but also interact with other system also like a telephonic system, which leads to unwanted interference between both the systems. Let's consider an unbalanced 3 phase distribution system model and understand the concepts and analyses it mathematically. FIG 2.1 displays a 3-Ø line section and the line parameters can be achieved by the technique developed by Carson and Lewis. A  $4 \times 4$  matrix, which describe the couplings effects of self and mutual impedances of the un-balanced 3-Ø line section, can be expressed as:

$$[Z_{abcn}] = \begin{bmatrix} Z_{aa} & Z_{ab} & Z_{ac} & Z_{an} \\ Z_{ba} & Z_{bb} & Z_{bc} & Z_{bn} \\ Z_{ca} & Z_{cb} & Z_{cc} & Z_{cn} \\ Z_{na} & Z_{nb} & Z_{nc} & Z_{nn} \end{bmatrix} \quad (1)$$

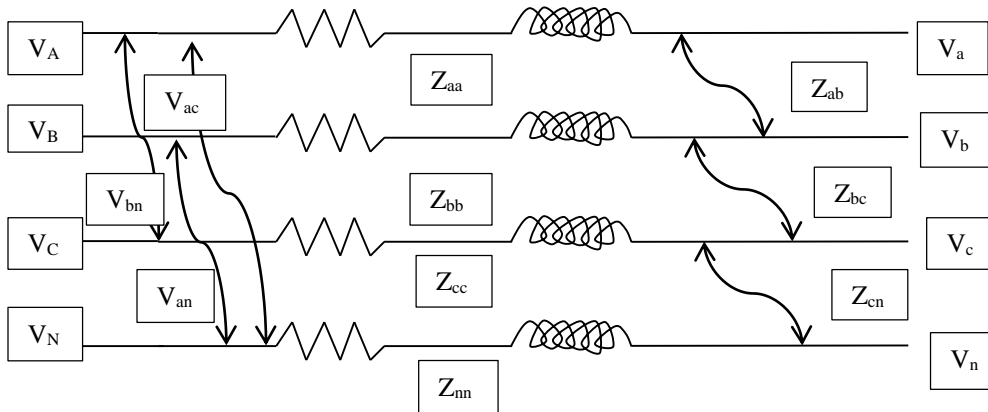

FIG 2.1: Three phase line section model

After applying Kron's reduction technique, and including the effects of the ground or neutral wire the model can be expressed as below:-

$$[Z_{abcn}] = \begin{bmatrix} Z_{aa-n} & Z_{ab-n} & Z_{ac-n} \\ Z_{ba-n} & Z_{bb-n} & Z_{bc-n} \\ Z_{ca-n} & Z_{cb-n} & Z_{cc-n} \end{bmatrix} \quad (2)$$

The relationship between bus voltages and branch currents can be articulated as:-

$$\begin{bmatrix} V_a \\ V_b \\ V_c \end{bmatrix} = \begin{bmatrix} V_A \\ V_B \\ V_C \end{bmatrix} - \begin{bmatrix} Z_{aa-n} & Z_{ab-n} & Z_{ac-n} \\ Z_{ba-n} & Z_{bb-n} & Z_{bc-n} \\ Z_{ca-n} & Z_{cb-n} & Z_{cc-n} \end{bmatrix} \begin{bmatrix} I_{Aa} \\ I_{Bb} \\ I_{Cc} \end{bmatrix} \quad (3)$$

In case any phase is absent, such as the case of two phase or single phase feeder sections, the equivalent row and column in this matrix will contain zero values. For 2- $\emptyset$  line sections with a-b, b-c and a-c phases, the relationship between 2- $\emptyset$  bus voltages and branch currents can be expressed as:-

$$\begin{bmatrix} V_a \\ V_b \end{bmatrix} = \begin{bmatrix} V_A \\ V_B \end{bmatrix} - \begin{bmatrix} Z_{aa-n} & Z_{ab-n} \\ Z_{ba-n} & Z_{bb-n} \end{bmatrix} \begin{bmatrix} I_{Aa} \\ I_{Bb} \end{bmatrix} \quad (4)$$

$$\begin{bmatrix} V_b \\ V_c \end{bmatrix} = \begin{bmatrix} V_B \\ V_C \end{bmatrix} - \begin{bmatrix} Z_{bb-n} & Z_{bc-n} \\ Z_{cb-n} & Z_{cc-n} \end{bmatrix} \begin{bmatrix} I_{Bb} \\ I_{Cc} \end{bmatrix} \quad (5)$$

$$\begin{bmatrix} V_a \\ V_c \end{bmatrix} = \begin{bmatrix} V_A \\ V_C \end{bmatrix} - \begin{bmatrix} Z_{aa-n} & Z_{ac-n} \\ Z_{ca-n} & Z_{cc-n} \end{bmatrix} \begin{bmatrix} I_{Aa} \\ I_{Cc} \end{bmatrix} \quad (6)$$

In case of 1- $\emptyset$  line sections:

$$V_{ia} = V_{ja} + Z_{aa-n} \times I_{ij-a} \quad (7)$$

$$V_{ib} = V_{jb} + Z_{bb-n} \times I_{ij-b} \quad (8)$$

$$V_{ic} = V_{jc} + Z_{cc-n} \times I_{ij-c} \quad (9)$$

The models mentioned for multi-phase distribution systems are considered in the subsequent sections for load flow.

# **CHAPTER 3**

## **FORWARD-BACKWARD SWEEP LOAD FLOW METHOD**



### 3.1 Forward-Backward Sweep Load Flow Method:

Before we start our discussion, let us familiarize ourselves with classification of buses, then heads to the backward forward sweep method.

**Load flow analysis:** - Load flow solution is a solution of networks under steady state condition subject to certain inequality constraints. These constraints can be load nodal voltage, reactive power of the generator and tap setting of the transformer etc.

Load flow solution works for both balanced and unbalanced condition.

Table 3.1: Classification of buses:-

Bus type	Quantities specified	Quantities to be obtained
Load Bus	P,Q	$ V , \delta$
Generator Bus	P, V	Q, $\delta$
Slack Bus	$ V , \delta$	P,Q

#### Formulation of Y- bus matrix:-

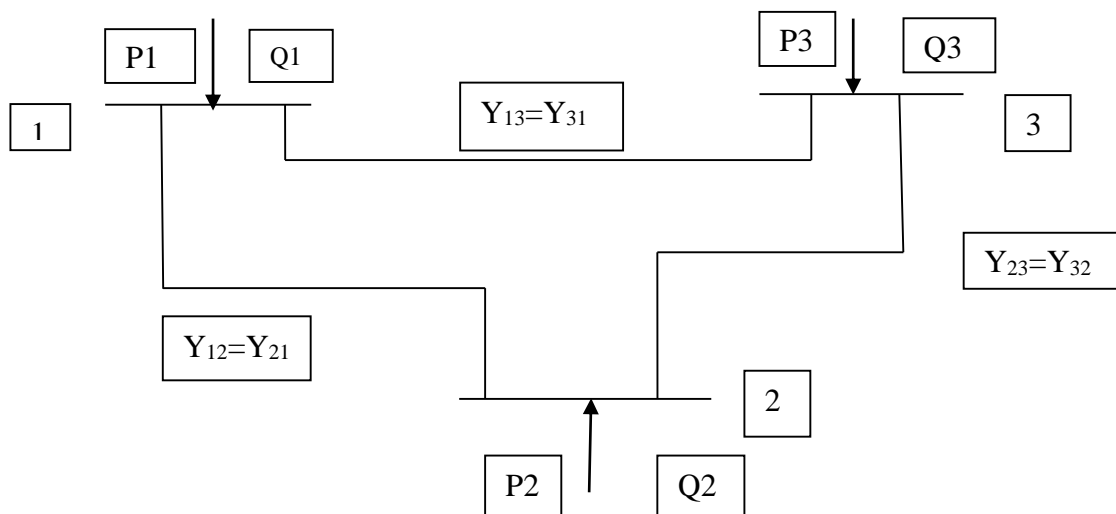

Fig. 3.1 THREE BUS POWER SYSTEM NETWORK

### 3.2 Backward Sweep:-

The aim of backward sweep is to update branch currents in each section, by considering the previous iteration voltages at each node.

During backward transmission, voltage values are held constant with updated branch currents transmitted backward along the feeder using backward path.

The Backward sweep starts from the extreme end branch and proceeds towards the slack bus.

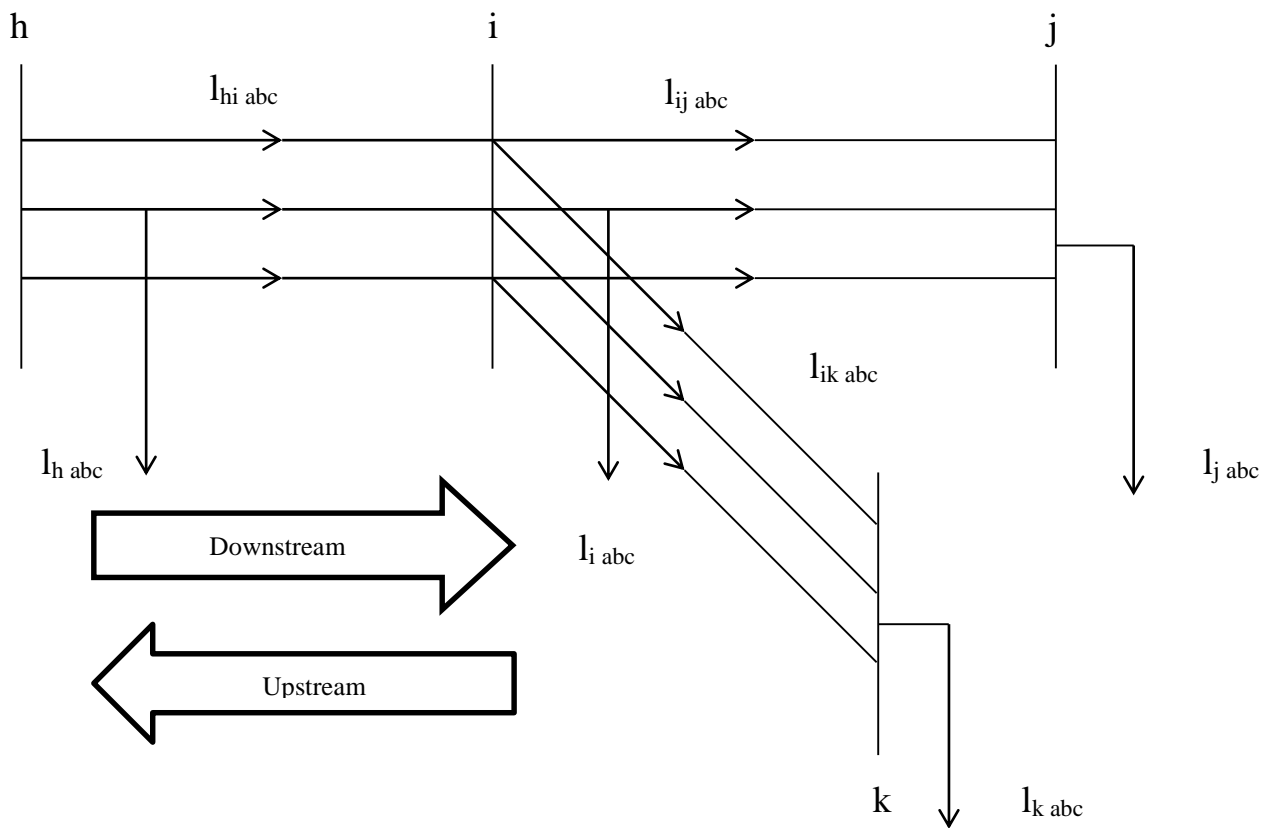

Fig 3.1 Three phase line section.

For branch currents preceding the end buses, the equation shown below is used,

$$I_{ij}^{abc} = I_j^{abc} \tag{10}$$

$$I_{ik}^{abc} = I_k^{abc}$$

These are the currents in branches i-j or i-k, preceding end buses j or k respectively.

For intermediate buses, the following equation is used,

$$I_{hi}^{abc} = I_{ij}^{abc} + I_{ik}^{abc} + I_i^{abc} \quad (11)$$

$$I_{hi}^{abc} = \sum_r I_{ir}^{abc} + I_i^{abc}$$

Where,

$r$  = all those buses connected to 'i' downstream.

$I_{hi}^{abc}$  = Branch current vector between bus h and i.

$I_{ij}^{abc}$  = Branch current vector between bus i and j.

$I_{ik}^{abc}$  = Branch current vector between bus i and k.

### 3.3 Forward Sweep:-

The aim of the forward sweep is to calculate the voltages at each node starting from the source node.

The source node is set as unity. and other node voltages are calculated as,

$$vb_i = vb_{i-1} - Ib_i * z_i - Ib_i * z_{mutual_i} \quad (12)$$

Where,

$vb_i$  = voltage of ith bus.

$vb_{i-1}$  = voltage of (i-1) th bus.

$z_{mutual_i}$  = mutual impedance.

Mutual impedance will be present for both three phase and two phase, but it is absent for single phase.

### 3.4 Forward Backward Sweep Method Algorithm:-

Step 1: Read input data i.e. the line data and the load data.

Step 2: From the data, vectors bp[m], adb[m], mf[m] and mt[m] are formed. Vector bp[m] stores the bus phases of all the buses of radial distribution grid. adb[m] with dimension double that of number of branches, stores adjacent buses of each of the buses.

mf[m], mt[m] = acts as a pointer to adb[m]; they store the starting and ending memory location of bus k in adb[m]; m=1,2,...,nb; nb= no. of buses.

Step 3: The magnitude of voltages is estimated as 1 p.u. for all buses, and angle 0 degree for phase ~a,-120 degree for phase~b and 120 degree for phase~c.

Step 4: Set K=1 (iteration counter).

Step 5: Find Equivalent current injection,

$$I_i^k = \left( \frac{P_i + jQ_i}{v_i^k} \right)^* ; \text{for } i = 2 \text{ to } i = nb. \quad (13)$$

Step 6: For calculating branch current, a backward sweep from bus i= nb is carried out, using equation (1) and (2).

Step 7: Set i= 2.

Step 8: To update magnitude and angles of bus voltage, forward sweep is applied.

Step 9: Set i=i+1.

Step 10: Check for i=nb, if yes step 11 is followed else step 8 is followed.

Step 11: Convergence is checked, for each of bus voltage magnitude by comparing with the values of previous iteration. If convergence is achieved, then step 13 is followed else step 12 is followed.

Step 12: K=K+1 and go to step 5.

Step 13: Print voltage magnitude in per unit and angles in radians at each bus.

### 3.5 Flow-chart of unbalanced radial distribution load flow:

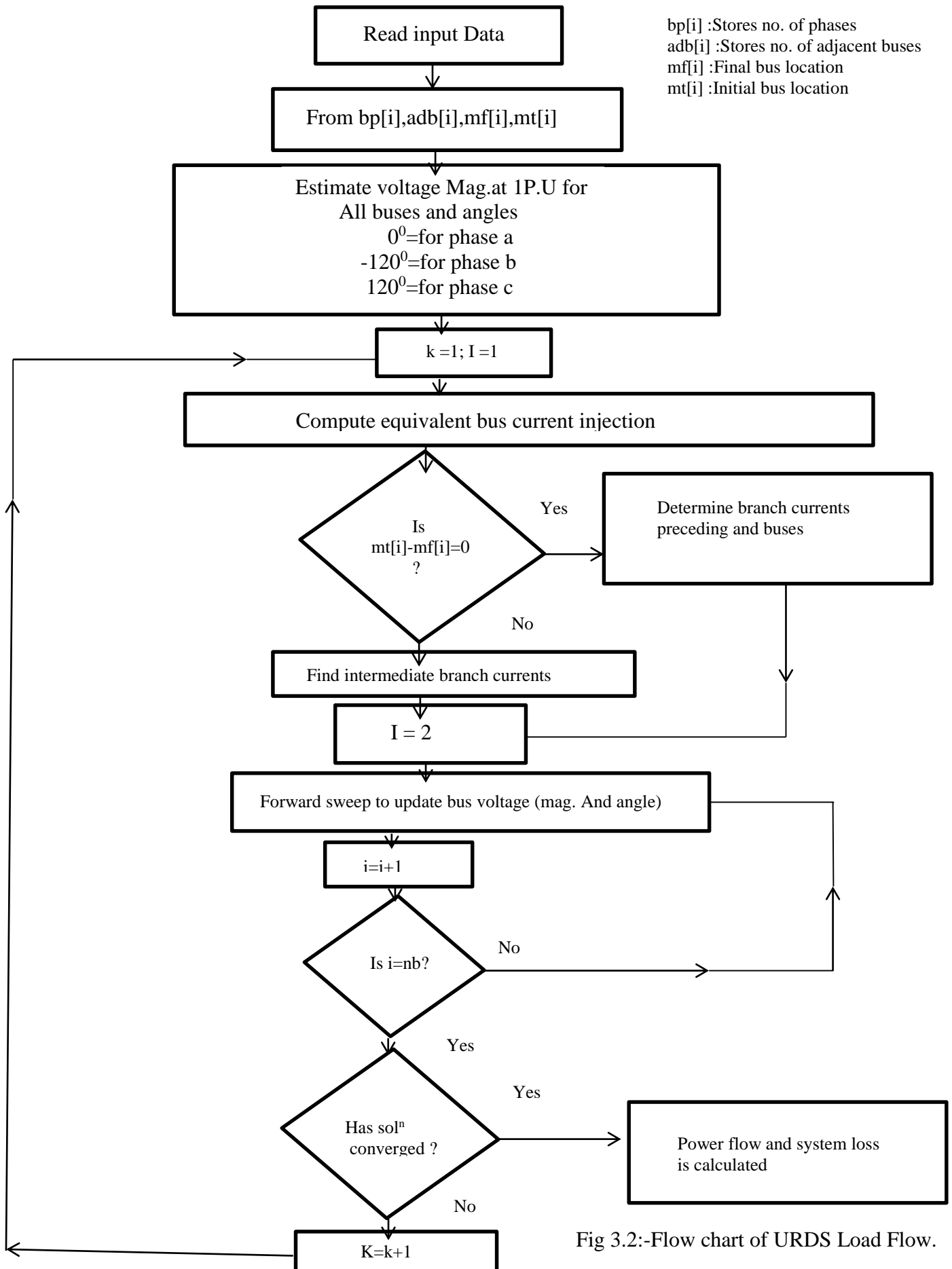

Fig 3.2:-Flow chart of URDS Load Flow.

# **CHAPTER 4**

## **RESULTS AND DISCUSSIONS**

## 4.1 RESULTS AND DISCUSSIONS

To study the load flow analysis of unbalanced distribution system; the very nature of balanced load's study is essential. In unbalanced system, we consider the fact of mutual impedance, hence the voltage drop by mutual impedance. The bus voltages and the angles of each phase are the results obtained from MATLAB and it is shown in tabular form. In the end, power loss of the line is calculated by square of the branch current multiply with the real component of the corresponding impedance. The efficiency of the line after reducing the loss, is more than 99%.

This method computes the power flow solution for its given radial network with its loadings and illustrated with 8 bus and 19 bus system of unbalanced radial distribution system. Also the total power and total line loss at phase a, phase b and phase c are found out and tabulated for both 19 bus as well as 8 bus Unbalanced Radial Distribution System.

The base value considered is mentioned below:

Base KVA= 1000;

Base KV= 11;

Considering these base values the data sheet is prepared and shown in tabular form in the Appendix section

## 19 BUS SYSTEM:-

The line data and load data are given in Appendix. For the load flow of 19 bus system, the base KV and base KVA are chosen as 11KV and 1000KVA respectively.

**TABLE 4.1: VOLTAGE AND PHASE ANGLES OF 19 BUS URDS:-**

BUS NO.	PHASE A		PHASE B		PHASE C	
	Va (PU)	<Va(rad) angle	Vb (PU)	<Vb(rad) angle	Vc (PU)	<Vc(rad) angle
1	1.000	0	1.000	-2.09	1.0000	2.09
2	0.9959	0.001	0.9964	-2.0943	0.9961	2.0947
3	0.9953	0	0.9963	-2.0943	0.9955	2.0949
4	0.9957	0.001	0.9964	-2.0943	0.9959	2.0948
5	0.9956	0.001	0.9963	-2.0943	0.9959	2.0948
6	0.9956	0.001	0.9963	-2.0943	0.9959	2.0948
7	0.9954	0	0.9961	-2.0942	0.9957	2.0947
8	0.9953	0.001	0.9961	-2.0942	0.9956	2.0947
9	0.9931	0.002	0.9936	-2.0940	0.9931	2.0947
10	0.9900	0.003	0.9902	-2.0938	0.9897	2.0948
11	0.9896	0.003	0.9898	-2.0937	0.9891	2.0949
12	0.9896	0.003	0.9898	-2.0937	0.9891	2.0949
13	0.9880	0.004	0.9880	-2.0936	0.9876	2.0949
14	0.9892	0.003	0.9894	-2.0937	0.9888	2.0949
15	0.9894	0.003	0.9895	-2.0936	0.9887	2.0949
16	0.9893	0.003	0.9895	-2.0936	0.9887	2.0949
17	0.9888	0.003	0.9889	-2.0937	0.9883	2.0949
18	0.9887	0.003	0.9888	-2.0936	0.9882	2.0949
19	0.9891	0.003	0.9890	-2.0936	0.9884	2.0948



TABLE 4.2: TOTAL POWER AND TOTAL LINE LOSS OF 19 BUS URDS IN kW

SL. NO.	PHASE	TOTAL POWER IN kW	TOTAL LINE LOSS IN kW
1.	A	140.3866	2.0995
2.	B	129.2641	2.0843
3.	C	136.9657	2.1290

## 08 BUS SYSTEM

The line data and load data are given in Appendix.

For the load flow of 8 bus system, the base KV and base KVA are chosen as 11KV and 1000KVA respectively.

TABLE 4.3: VOLTAGE AND PHASE ANGLES OF 8 BUS URD

BUS NO.	PHASE A		PHASE B		PHASE C	
	Va (PU)	<Va(rad) angle	Vb (PU)	<Vb(rad) angle	Vc (PU)	<Vc(rad) angle
1	1.000	0	1.000	-2.09	1.0000	2.09
2	0.9994	-0.0002	0.9997	-2.0942	0.9987	2.0945
3	0	0	0.9991	-2.0938	0.9975	2.0943
4	0	0	0	0	0.9973	2.0943
5	0	0	0	0	0.9974	2.0943
6	0	0	0	0	0.9975	2.0943
7	0.9994	-0.0002	0	0	0	0
8	0	0	0.9997	-2.0942	0	0

TABLE 4.4: TOTAL POWER AND TOTAL LINE LOSS OF 8 BUS URDS IN kW

SL. NO.	PHASE	TOTAL POWER IN kW	TOTAL LINE LOSS IN kW
1.	A	1115.9	1.0778
2.	B	872.5751	1.0767
3.	C	1884.3	3.9264

## **CONCLUSION:-**

In this report, a direct method for distribution load flow solution is presented to solve load flow problem by using two matrices, BIBC and BCBV. BIBC is abbreviated form of bus injection to branch currents, and the BCBV stands for branch currents to bus voltages. These two matrices are collectively used to form a direct approach to solve the load flow problems in case of balanced distribution system.

For unbalanced distribution system backward sweep is used for calculation of branch current and forward sweep is used for bus voltage. The results of 8 bus unbalanced 3 phase radial distribution system and 19 bus unbalanced 3 phase radial distribution system is shown to demonstrate the algorithm.

## REFERENCES:-

- [1] K. A. Birt, J. J. Graffy, J. D. McDonald, and A. H. El-Abiad, "Three phase load flow program," IEEE Trans. Power Appar. Syst., vol. PAS-95, pp. 59–65, Jan. /Feb. 1976
- [2] T.-H. Chen, M.-S.Chen, K.-J. Hwang, P. Kotas, and E. A. Chebli, "Distribution system power flow analysis—A rigid approach," IEEE Trans. Power Delivery, vol. 6, pp. 1146–1152, July 1991.
- [3] R. D. Zimmerman and H. D. Chiang, "Fast decoupled power flow for unbalanced radial distribution systems," IEEE Trans. Power Syst., vol. 10, pp. 2045–2052, Nov. 1995.
- [4] W. M. Kersting and L. Willis, "Radial Distribution Test Systems, IEEE Trans. Power Syst.," vol. 6, IEEE Distribution Planning Working Group Rep., Aug. 1991.
- [5] C. S. Cheng and D. Shirmohammadi, "A three-phase power flow method for real-time distribution system analysis," IEEE Trans. Power Syst., vol. 10, pp. 671–679, May 1995.
- [6] D. Shirmohammadi, H. W. Hong, A. Semlyen, and G. X. Luo, "A compensation-based power flow method for weakly meshed distribution and transmission networks," IEEE Trans. Power Syst., vol. 3, pp. 753–762, May 1988.
- [7] T. S. Chen, M. S. Chen, T. Inoue, and E. A. Chebli, "Three- phase co-generator and transformer models for distribution system analysis," IEEE Trans. Power Delivery, vol. 6, pp. 1671–1681.2, Oct. 1991.
- [8] G. X. Luo and A. Semlyen, "Efficient load flow for large weakly meshed networks," IEEE Trans. Power Syst., vol. 5, pp. 1309–1316, Nov. 1990.
- [9] W. M. Lin and M. S. Chen, "An overall distribution automation structure," Elect. Power Syst. Res., vol. 10, pp. 7–19, 1986

## APPENDIX:

### 5.1 Datasheet of 19 bus unbalanced radial distribution system:

#### Load data:

SL.NO.	BUS NO.	PHASE A(PU)	PHASE B(PU)	PHASE C(PU)
1.	2	0.01038+0.00501i	0.00519+0.00252i	0.01038+0.00501i
2.	3	0.01101+0.00534i	0.00519+0.00252i	0.00972+0.00471i
3.	4	0.00405+0.00195i	0.00567+0.00276i	0.00648+0.00315i
4.	5	0.00648+0.00315i	0.00519+0.00252i	0.00453+0.00219i
5.	6	0.00420+0.00204i	0.00309+0.00150i	0.00291+0.00141i
6.	7	0.00972+0.00471i	0.00810+0.00393i	0.00810+0.00393i
7.	8	0.00744+0.00360i	0.00534+0.00258i	0.00339+0.00165i
8.	9	0.01230+0.00597i	0.01491+0.00723i	0.01329+0.00642i
9.	10	0.00339+0.00165i	0.00420+0.00204i	0.00258+0.00126i
10.	11	0.00744+0.00360i	0.00744+0.00360i	0.01101+0.00534i
11.	12	0.00972+0.00471i	0.00810+0.00393i	0.00810+0.00393i
12.	13	0.00438+0.00213i	0.00534+0.00258i	0.00648+0.00315i
13.	14	0.00309+0.00150i	0.00309+0.00234i	0.00405+0.00195i
14.	15	0.00438+0.00213i	0.00486+0.00234i	0.00696+0.00336i
15.	16	0.00777+0.00378i	0.01038+0.00501i	0.00777+0.00378i
16.	17	0.00648+0.00315i	0.00486+0.00234i	0.00486+0.00234i
17.	18	0.00543+0.00258i	0.00534+0.00258i	0.00552+0.00267i
18.	19	0.00876+0.00423i	0.01005+0.00486i	0.00714+0.00345i

**Line data (self-impedance):**

SL. NO.	FROM	TO	PHASE A(PU)	PHASE B(PU)	PHASE C(PU)
1.	1	2	0.0387+0.01665i	0.0387+0.01665i	0.0387+0.01665i
2.	2	3	0.0645+0.02775i	0.0645+0.02775i	0.0645+0.02775i
3.	2	4	0.01935+0.008325i	0.01935+0.008325i	0.01935+0.008325i
4.	4	5	0.01935+0.008325i	0.01935+0.008325i	0.01935+0.008325i
5.	4	6	0.0129+0.00555i	0.0129+0.00555i	0.0129+0.00555i
6.	6	7	0.0258+0.0111i	0.0258+0.0111i	0.0258+0.0111i
7.	6	8	0.03225+0.013875i	0.03225+0.013875i	0.03225+0.013875i
8.	8	9	0.0387+0.01665i	0.0387+0.01665i	0.0387+0.01665i
9.	9	10	0.0645+0.02775i	0.0645+0.02775i	0.0645+0.02775i
10.	10	11	0.01935+0.008325i	0.01935+0.008325i	0.01935+0.008325i
11.	10	12	0.01935+0.008325i	0.01935+0.008325i	0.01935+0.008325i
12.	11	13	0.0645+0.02775i	0.0645+0.02775i	0.0645+0.02775i
13.	11	14	0.0129+0.00555i	0.0129+0.00555i	0.0129+0.00555i
14.	12	15	0.0645+0.02775i	0.0645+0.02775i	0.0645+0.02775i
15.	12	16	0.0774+0.0333i	0.0774+0.0333i	0.0774+0.0333i
16.	14	17	0.04515+0.019425i	0.04515+0.019425i	0.04515+0.019425i
17.	14	18	0.0516+0.0222i	0.0516+0.0222i	0.0516+0.0222i
18.	15	19	0.0516+0.0222i	0.0516+0.0222i	0.0516+0.0222i

**Line data (mutual impedance):**

NBR	BC( $\times 10^{-3}$ ) (PU)	AB( $\times 10^{-3}$ ) (PU)	AC( $\times 10^{-3}$ ) (PU)
1	12.9+5.55i	12.9+5.55i	12.9+5.55i
2	21.5+9.25i	21.5+9.25i	21.5+9.25i
3	6.45+2.775i	6.45+2.775i	6.45+2.775i
4	6.45+2.775i	6.45+2.775i	6.45+2.775i
5	4.3+1.85i	4.3+1.85i	4.3+1.85i
6	8.6+3.7i	0.09189+0.9314i	5.385+4.747i
7	10.75+4.625i	0.07351+0.7451i	4.308+3.797i
8	12.9+5.55i	12.9+5.55i	12.9+5.55i
9	21.5+9.25i	21.5+9.25i	21.5+9.25i
10	6.45+2.775i	6.45+2.775i	6.45+2.775i
11	6.45+2.775i	6.45+2.775i	6.45+2.775i
12	21.5+9.25i	21.5+9.25i	21.5+9.25i
13	4.3+1.85i	4.3+1.85i	4.3+1.85i
14	21.5+9.25i	21.5+9.25i	21.5+9.25i
15	25.8+11.1i	25.8+11.1i	25.8+11.1i
16	15.05+6.475i	15.05+6.475i	15.05+6.475i
17	17.2+7.4i	17.2+7.4i	17.2+7.4i
18	17.2+7.4i	17.2+7.4i	17.2+7.4i

## 5.2 Datasheet of 8 bus unbalanced radial distribution system:

### Load data:

SL.NO.	BUS NO.	PHASE A(PU)	PHASE B(PU)	PHASE C(PU)
1.	2	0.519+0.250i	0.259+0.126i	0.515+0.250i
2.	3	0	0.259+0.126i	0.486+0.235i
3.	4	0	0	0.324+0.157i
4.	5	0	0	0.226+0.109i
5.	6	0	0	0.145+0.070i
6.	7	0.486+0.235i	0	0
7.	8	0	0.267+0.129i	0

### Line data (self-impedance):

SL.NO.	FROM	TO	PHASE A( $\times 10^{-4}$ )	PHASE B( $\times 10^{-4}$ )	PHASE C( $\times 10^{-4}$ )
1.	1	2	7.74+3.33i	7.74+3.33i	7.74+3.33i
2.	2	3	0	12.9+5.55i	12.9+5.55i
3.	2	5	0	0	3.87+1.665i
4.	2	7	3.87+1.665i	0	0
5.	3	4	0	0	2.58+1.11i
6.	3	8	0	5.16+2.22i	0
7.	5	6	0	0	6.45+2.775i

### Line data (mutual impedance):

NBR	BC( $\times 10^{-4}$ ) (PU)	AB( $\times 10^{-4}$ ) (PU)	AC( $\times 10^{-4}$ ) (PU)
1	2.58+1.11i	2.58+1.11i	2.58+1.11i
2	4.3+1.85i	0	0
3	0	0	0
4	0	0	0
5	0	0	0
6	0	0	0
7	0	0	0