

Energy Conservation Clustering in Wireless Sensor Networks for Increased Life Time

Madhu Sudan Tinker

(Roll No: 213CS1154)



**Department of Computer Science and Engineering
National Institute of Technology, Rourkela
Rourkela-769 008, Odisha, India
May, 2015.**

Energy Conservation Clustering in Wireless Sensor Networks for Increased Life Time

*Thesis submitted in partial fulfillment
of the requirements for the degree of*

Master of Technology

in

Computer Science and Engineering

by

Madhu Sudan Tinker

(Roll No: 213CS1154)

under the guidance of

Prof. Suchismita Chinara

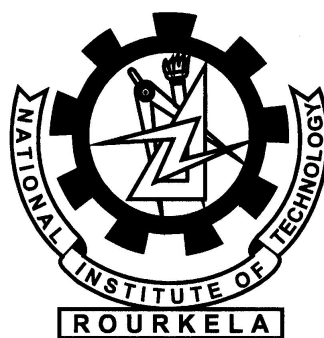

**Department of Computer Science and Engineering
National Institute of Technology, Rourkela
Rourkela-769 008, Odisha, India
May, 2015.**

dedicated to my parents and teachers...

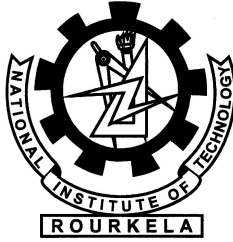

Department of Computer Science and Engineering
National Institute of Technology Rourkela
Rourkela-769 008, Odisha, India.

Certificate

This is to certify that the work in the thesis entitled "*Energy Conservation Clustering in Wireless Sensor Networks for Increased Life Time*" submitted by *Madhu Sudan Tinker* is a record of an original research work carried out by him under my supervision and guidance in partial fulfillment of the requirements for the award of the degree of Master of Technology in Computer Science and Engineering, National Institute of Technology, Rourkela. Neither this thesis nor any part of it has been submitted for any degree or academic award elsewhere.

Place: NIT, Rourkela-769008
Date: May, 2015

Prof. Suchismita Chinara
Assistant Professor
Department of CSE
National Institute of Technology
Rourkela-769008

Acknowledgement

First of all, I would like to express my deep sense of respect and gratitude towards my supervisor Prof Suchismita Chinara, who has been the guiding force behind this work. I want to thank her for introducing me to the field of wireless sensor networks and giving me the opportunity to work under her guidance. Her undivided faith in this topic and ability to bring out the best of analytical and practical skills in people has been invaluable in tough periods. Without her invaluable advice and assistance it would not have been possible for me to complete this thesis. I am greatly indebted to her for her constant encouragement and invaluable advice in every aspect of my academic life. I consider it my good fortune to have got an opportunity to work with such a wonderful person.

I wish to thank all faculty members and secretarial staff of the CSE Department for their sympathetic cooperation.

During my studies at N.I.T. Rourkela, I made many friends. I would like to thank them all, for all the great moments I had with them.

When I look back at my accomplishments in life, I can see a clear trace of my family's concerns and devotion everywhere. My dearest mother, whom I owe everything I have achieved and whatever I have become; my beloved father, for always believing in me and inspiring me to dream big even at the toughest moments of my life; and my brother and sister; who were always my silent support during all the hardships of this endeavor and beyond.

Madhu Sudan Tinker

Abstract

Energy has always been the main issue for wireless sensor networks because in many situations battery recharging or replenishment is not possible. Many solutions have been provided for energy conservation. Clustering protocols have been successful for solving this issue to an extent but are not perfect. In our proposed algorithm we utilize the ability of the sensor nodes to control their transmission power range. By utilizing this ability we are able to minimize their intra cluster energy. Although this is local energy saving but this leads us to minimization of overall network energy consumption. The other thing that can be considered is about the task of a cluster head in clustering algorithms where cluster-head is doing the task as transmitter and receiver simultaneously. Providing these tasks to a single node is not efficient. So we are introducing the notion of a special node called s-node where this s-node is working as a transmitter for a cluster and sending the aggregated data to the sink. We have simulated the proposed scheme with LEACH and LEACH-C protocol and simulation results show that the proposed scheme is better in terms of network life time than both protocols.

Keywords: Clustering; Network Life Time; Optimization; S-Node; Signal Strength; Wireless Sensor Networks

Contents

Certificate	ii
Acknowledgement	iii
Abstract	iv
List of Figures	vii
List of Tables	viii
List of Acronyms	ix
1 Introduction	2
1.1 Introduction	2
1.1.1 Architecture Of Sensor Node	3
1.1.2 Protocol Stack For WSNs	4
1.2 Comparision between WSNs And Wireless Ad-hoc Networks	6
1.3 Challenges in Wireless Sensor Network	7
1.4 Applications Of WSNs	9
1.5 Motivation	10
1.6 Objectives of Research	11
1.7 Organisation of Thesis	11
2 Literature Survey	13
2.1 Key Problems Of Routing Protocols	13
2.2 Review of WSNs Hierarchical routing protocols	14
3 Proposed Algorithm	19
3.1 Energy Model and Basic Assumptions	19
3.2 Proposed Scheme	19

3.2.1	Tune-up Phase	22
3.2.2	Cluster-head and s-node election phase	22
3.2.3	Cluster Formation	23
4	Simulation and Analysis	26
4.1	Simulation Environment	26
4.2	Simulation Analysis	27
5	Conclusion and Future Work	31

List of Figures

1.1	general scenario of Wireless Sensor Network	3
1.2	Sensor Node's Architecture	4
1.3	Protocol stack for WSN	4
2.1	LEACH phases: setup and steady state phase	15
2.2	A simple cluster scheme	16
2.3	Radio energy dissipation model	16
3.1	Tune-up phase, Cluster head and s-node election phase, cluster formation phase	21
3.2	Flow Chart of Proposed Scheme	24
4.1	Number of alive nodes (100 nodes)	28
4.2	Number of alive nodes (300 nodes)	28
4.3	Energy dissipation for 100 nodes	29
4.4	Energy dissipation for 300 nodes	29

List of Tables

4.1	Simulation Parameters	27
-----	---------------------------------	----

List of Acronyms

Acronym	Description
BS	Base Station
CHs	Cluster Heads
WSNs	Wireless Sensor Networks
WANETs	Wireless Ad-hoc Networks

Chapter 1

Introduction

Introduction

Comparison between WSNs and WANETs

Challenges in WSNs

Applications Of WSNs

Motivation

Objectives of Research

Organization of Thesis

Chapter 1

Introduction

This chapter describes the overview of the thesis. Part 1.1 gives basic introduction about wireless sensor networks and part 1.2 describes the comparison between WSNs and WANET (wireless ad-hoc networks). Part 1.3 explains the challenges present in wireless sensor networks and applications of WSNs is described in part 1.4. The motivation for the work is given in part 1.5. Objectives of Research is given in part 1.6 and part 1.7 describes the organization of the thesis.

1.1 Introduction

A wireless sensor network is made up of small autonomous sensing devices also called as nodes for sensing different physical and environmental conditions such as temperature, sound, pressure etc. and cooperatively passes their data through the network to a main location or base station. The development of wireless sensor networks was motivated by military applications such as battlefield surveillance and today such networks are used in many industrial and consumer applications, such as industrial process monitoring and control, machine health monitoring etc.

Recent advancement in micro-electronics technology facilitated sensor designers to develop low price, low power and small sized sensors. Thousand of sensor are deployed in order to achieve high quality network. In the recent few years WSNs has emerged as an important technology for monitoring physical environment. WSNs consist of large number of sensor nodes which are small in size, inexpensive and battery powered. These WSNs can be used in various applications such as Military surveillance, environment monitoring, border protection, health care monitoring, weather monitoring. These applications re-

quire data without delay and energy consumed by them should be small. WSNs are deployed in harsh environment. Since it is not possible to replace or charge battery of sensor nodes, So it is desirable to design communication protocols such that energy source is used effectively and the delay in the network in minimum.

Sensor nodes senses the environment, gathers the data from its surrounding (computation) and communicates it to the base station (BS). Out of the three tasks communication takes large amount of battery power of a sensor node, so the major concern is the communication task. We have to minimize the communication cost in order to save battery power.

Wireless sensor networks [1] consists of a thousands of sensor nodes which are deployed randomly in environment or space. In sensor network there is a BS (base station) which is located far away from the sensor field. Sensor nodes sends the sensed data to the BS. For sending the sensed data to BS directly a lot of energy is consumed. So it is desirable to develop some protocols to minimized this communication cost. Energy conservation and maximization of network lifetime are the key challenges in the design and implementation of WSNs. The following figure shows the general scenario of wireless sensor networks.

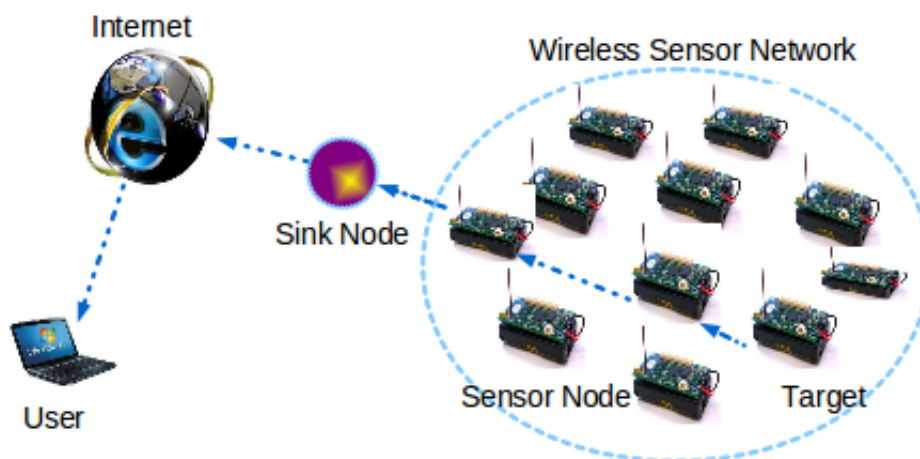

Figure 1.1: general scenario of Wireless Sensor Network

1.1.1 Architecture Of Sensor Node

Every sensor node mainly consists of four components. They are sensing unit, transceiver, processing unit and power source. Some sensor nodes also consist of optional components like loca-

tion finding system, power generator and mobilizer.

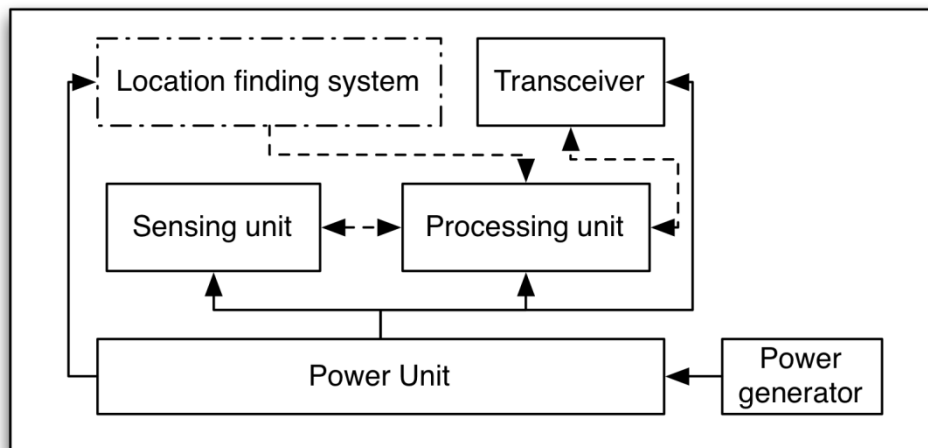

Figure 1.2: Sensor Node's Architecture

The sensing unit generally consist of sensor and ADC(Analog to digital converter).The ADC converts the analog data to digital data so that node can process it before transmitting the data.Transceiver connects the node to the network.The processing unit consists of processor and memory.This unit is responsible for managing the task of sensor unit.Mobilizer is used to enable node movement.Figure 1.2 shows the architecture of a sensor node.

1.1.2 Protocol Stack For WSNs

Following figure shows the protocol stack of WSN.

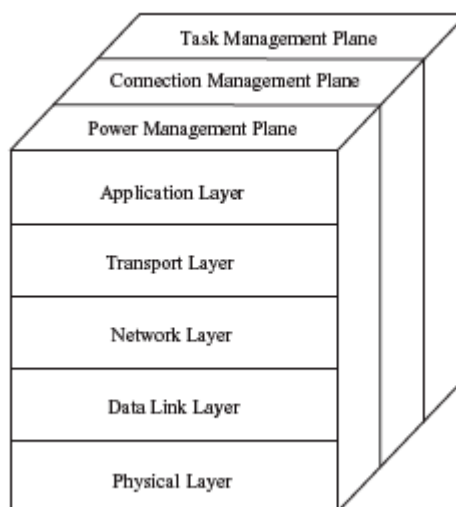

Figure 1.3: Protocol stack for WSN

Description of each layer is as follows:

- Physical Layer : This layer addresses the needs of robust modulation, receiving techniques and transmission.
- Data link layer: Minimize collision with the neighbouring broadcasts.
- Network layer: Various routing are performed here.
- Transport layer: Flow of data is being maintained here.
- Application layer: Various application software runs here depending upon sensing task.

Most important part of a sensor node is its battery power. So in order to increase the network life time it should be utilized properly. For this various methods have been proposed till now. Out of which Routing has utilized the sensors nodes energy very effectively.

The clustering routing protocols in wireless sensor networks are mainly considered as cross layering techniques for designing energy efficient hierarchical wireless sensor networks where the sensor nodes that are belong to a cluster, send their sensed data to a node belong to their cluster called cluster head and then the cluster head eliminates the correlated data to reduce final data volume and send the aggregated data to the data sink. The clustering approaches can increase network longevity and improve energy efficiency by minimizing overall energy consumption and balancing energy consumption among the nodes during the network life time. The clustering based protocols are classified with respect to the techniques they adapt to select cluster heads and transmitting the aggregated data to the data sink.

In order to transmit aggregated data to the data sink some protocols use single-hop communication which consumes a large quantity of energy and deteriorates energy balancing of nodes in the network since the nodes that are farther to the sink consume more energy due to relation between required energy to transmit the data and distance between sender and receiver. On other hand, multi hop approach also causes energy unbalancing. In this scheme the nodes that are closer to sink have higher traffic load which causes depleting the energy quickly.

There is much attention on energy efficiency of clustering protocols designed around cluster based network structure. The LEACH (low energy adaptive clustering hierarchy) protocol assumes that energy consumption is equal in nodes when they are selected as cluster heads and/or non-cluster heads. Therefore cluster head selection is based on random round robin. All non-cluster heads send their data to the closest cluster head. Then cluster heads send aggregated data to the data sink directly.

1.2 Comparison between WSNs And Wireless Ad-hoc Networks

- *Network Size:*

WSNs nodes varies from few hundred node to thousands of nodes but WANETs consist of limited no. of nodes i.e few hundreds of nodes. Bluetooth pico net is an example of WANET. WLAN is also example of WANET.

- *Network Density:*

Network density in WSNs is usually high, with big quantity of nodes are close to each other but in case of WANET very few nodes are close to each other. The size of nodes of WSN is very small. It is as small as one Euro coin but nodes of WANET are mostly laptops, palmtops, cellular phones etc.

- *Node Proneness To Failure:*

WSNs nodes are placed in inaccessible areas or isolated areas like forest or disaster areas. Nodes once deployed in this areas are very difficult to replace. The nodes may drain their energy or they may be damaged. But MANETS have rechargeable batteries in their nodes. These nodes are not subjected to difficult environmental conditions that could damage them.

- *Frequency Of Topology Change:*

Topology change frequency is high in WSNs because of node failure, node addition, node moving and environmental interference. The network has to adapt itself to the changing topology. Topology may change in few milli seconds in WSNs. In

WANETs, nodes join the network after request and then leave the network after some time, which is less than a minute.

- *Communication Paradigm Employed:*

WSNs use the mechanism of broadcasting in order to communicate with the other nodes but WANETs use point-to-point communication.

- *Resource Limitations Of nodes:*

The energy resources of WSN nodes cannot be replenished, because unlike WANETs the WSNs don't have rechargeable batteries. Once the nodes are deployed in the environment, they cannot be recharged or replaced. The memory of WSNs is a few kilobytes but that of WANETs is in gigabytes. The processors used in WSNs are a few MHz but that of WANETs is in GHz.

- *Node Identification:*

Node identification by globally unique identifiers is not always possible in WSNs, since the number of nodes in WSNs is very high and there is a possibility the nodes may exit the network very frequently. In WANETs nodes have unique identifiers like IP (Internet Protocol) addresses.

1.3 Challenges in Wireless Sensor Network

Challenges in wireless sensor networks arise in the implementation of several services. There are so many controllable and uncontrollable parameters by which the implementation of a wireless sensor network is affected such as:

- *Energy conservation:*

In a wireless sensor network every node is equipped with a sensor and the sensor devices are in working condition depending upon the power supplied by the attached battery. To have better performance the network should operate for a long time. As we know that the sensor node has a small size, due to this small size the battery has a low capacity and the available energy is very less and in that situation the refilling

or replacing of battery is impossible. It is a costly attempt. In order to avoid this problem some more energy efficient protocol are design so that the sensor node communicate efficiently by increasing both throughput and network capacity.

- *Application specific :*

Sensor network changes with change in application. For different type of application we have to design different sensor network.

- *Operation in antagonistic environment:*

Sensor network can be operating in antagonistic environmental condition. So design issues of sensor node are carefully considered. Protocol for the sensor network should be robust one. It silent about any fault occurs in system.

- *Communication quality:*

Sensor network have very low quality communication depending upon different situation like when it is operated in some unpleasant environment then communication quality is very poor. It is environment specific.

- *Availability of resources:*

When the resources required by sensor network are unavailable then the sensor networks try hard to provide the desired QoS.

- *Data processing:*

Data collected by many sensors may contain redundant data. So data aggregation is required in network processing so that redundant data can't be transmitted more number of time. It will help to conserve some amount of energy for further transmission.

- *Scalability :*

Wireless sensor node are composed of large number of sensor node and many more nodes can be added in design stage.

- *Commercialization :*

In recent scenario the production of sensor node started by many electronics based company. But commercialization very poor especially in case of sensor network. Profit issue is very less.

Traditional routing protocol for Ad-hoc network are not suitable for Wireless sensor network and the reason are given below :

- *Data centric:*

Data is requested based upon some attributes.

- *Data redundancy:*

In wireless sensor network every adjacent node may have similar data. Data aggregation required before sending the data. It minimizes the communication overhead.

- *Application specific:*

Wireless sensor network is different for different application.

1.4 Applications Of WSNs

WSNs are designed to perform high level information processing task. Sensor nodes are deployed in harsh environment. Sensor nodes senses the environmental conditions such as temperature, pressure etc and then it sends the sensed data to the BS. Application of sensor networks is very vast. Some of the applications of sensor networks are:

- *Intrusion Detection:*

Due to presence of less mobility and stationary property of wireless sensor network, it can be used to track object event. It can be used for security purposes that are for surveillance purposes. Generally high resolution camera is equipped with sensors that can be used to form a network that monitor a restricted area access. If any outsider enter into this region without any proper authentication then some sort of signaling event occur. It may be an alarm message quickly propagating to a handling authority.

- *Avalanche prediction:*

Movement of large snow masses can be predicted by device equipped with sensor. GPS can be one of the detecting devices used for this purpose.

- *Environmental condition monitoring:*

It includes sensing Volcanoes, oceans, Glaciers, forest.

- *Industrial monitoring:*

It includes Machine health monitoring, Factory.

- *Agriculture:*

Irrigation management, green houses.

- Battlefield awareness.

1.5 Motivation

The LEACH (low energy adaptive clustering hierarchy) has become the classical protocol for clustering algorithms which provide network longevity by dividing network into clusters [2] [3] but in most of the clustering protocols proposed in literature [4], each cluster head is a relay node for transmitting data to sink simultaneously and vice versa [5]. Employing nodes as cluster heads and relay node simultaneously is not optimum because sending and receiving, these two are the most energy consuming tasks in network operation and allocating these tasks to a common node at the same time will result in depletion of the node's energy level quickly [6]. This implies that simultaneous assignment of the role of sender and receiver to nodes is not a good option.

Energy consumption of nodes can also be managed by adjusting their transmission power levels. Intra cluster energy, which is the average energy consumption inside a cluster, can be reduced in this way and thus this local saving will result in network level energy reduction. The parameter 'number of neighbours' (degree) can be proposed in this context for the connectedness of the network.

1.6 Objectives of Research

There are various drawbacks of LEACH protocol. Some of the issues that we are addressing are listed below:

- efficient use of node's energy.
- improvement over intra-cluster energy consumption.
- energy efficient clustering.
- improving network life-time.

1.7 Organisation of Thesis

The rest of Thesis is organized as follow:

Chapter 2: In this chapter a brief overview of LEACH and some of its variants are discussed.

Chapter 3: In this chapter Proposed clustering scheme,cluster head selection,cluster formation scheme is discussed.

Chapter 4: In this chapter simulation results and implementation are shown with comparison to existing scheme.

Chapter 5: In this chapter we have concluded the thesis work.

Chapter 2

Literature Survey

Chapter 2

Literature Survey

In this chapter, the design consideration for wireless sensor networks routing protocols are discussed. Then some well known hierarchical WSNs routing protocols are discussed.

2.1 Key Problems Of Routing Protocols

To Design an algorithm for WSNs, following issues must be considered.

- Sensor nodes are battery-operated and most often constrained in energy due to the inability of recharging of nodes. Hence one of the important method in protocol design is the energy consumption.
- Sensor nodes should be sensitive and adaptive to the dynamic environment when they are deployed.
- A sensor network algorithm should be self organizing and distributive, since WSNs is infrastructure less.
- The security of the nodes should be considered.
- Scalability is another important factor to be considered when designing a topology for WSN.

Clustering routing protocols [4] have provided much longer network lifetime in contrast to flat routing protocol and location based routing protocol. In clustering routing protocol whole network is divided into number of clusters and one node in each cluster is the cluster-head which collects data from the sensor nodes within a cluster and then

aggregates the received data from sensor nodes, then transmits the aggregated data to the base station (BS).

Clustering advantages: Main advantage of clustering routing is that it reduces the number of packet or data transmission. Clustering protocols allow non-cluster head nodes to transmit data to shorter distance in order to save their energy. [7]

Advantages Of Data Aggregation : Various types of data aggregation have been proposed till date. In [17] a new data aggregation was introduced which compresses the data, originally inspired by [18]. The author of [17] discussed different data aggregation schemes: in-network, grid based, hybrid based. The most commonly used data aggregation such as in LEACH and LEACH like protocols assumes perfect aggregation in which multiple packets are sent from the cluster members to their respective cluster-heads but only a single copy is forwarded to the base station.

2.2 Review of WSNs Hierarchical routing protocols

In hierarchical clustering protocols [9] whole network is divided into several clusters. One node in each cluster is given a leading role which is called as cluster head. Usually cluster-head is the only node that can communicate to sink in clustering protocols [8]. This idea significantly reduces the transmission overhead of normal nodes because normal nodes have to transmit to cluster-head only.

A brief discussion about some of the hierarchical clustering protocols is given below [8][9].

In [2], Heinzelman proposed a clustering algorithm which is distributive in nature is called Low-Energy Adaptive Clustering Hierarchy (LEACH) protocol. LEACH selects nodes as cluster heads (CH) based on round-robin fashion for ensuring distributed energy consumption among all the nodes. The protocol assumes that the CH will always receive correlated data and it will aggregate this data before sending to data sink. It uses the concept of rounds. Every round in the protocol is having two phases as shown in fig. 2.1: set-up phase and steady-state phase.

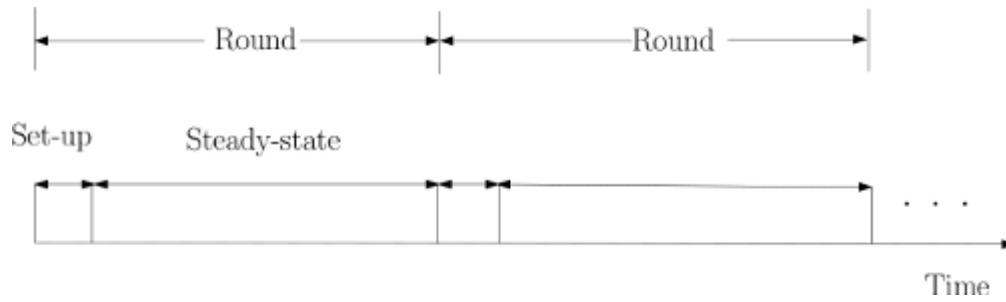

Figure 2.1: LEACH phases: setup and steady state phase

In the set-up phase, CH is selected and clusters are formed, and in the steady state, the data transfer to sink is done. In set-up phase, a predetermined fraction of nodes generate a random number between 0 and 1. If the random number is less than a threshold then the node becomes a CH, otherwise the node is expected to join the nearest cluster head in its neighborhood. The threshold value is given by expression:

$$T_n = \begin{cases} \frac{p}{1-p(r \bmod (\frac{1}{p}))}, & \text{if } n \in G \\ 0, & \text{otherwise} \end{cases} \quad (2.1)$$

Where r is the current round, p is the probability for each node to become CH and G is the set of nodes that have not been cluster-head in the past rounds. Besides all of the advantages of LEACH, it also has some disadvantages. LEACH assumes that data can be transmitted with highest transmission power by all nodes to reach the sink which results in high intra cluster energy consumption. LEACH doesn't support large network areas. In addition to it, in leach every node has equal chance of being cluster head and it does not ensure fair distribution of cluster heads. Fig. 2.2 shows leach communication hierarchy.

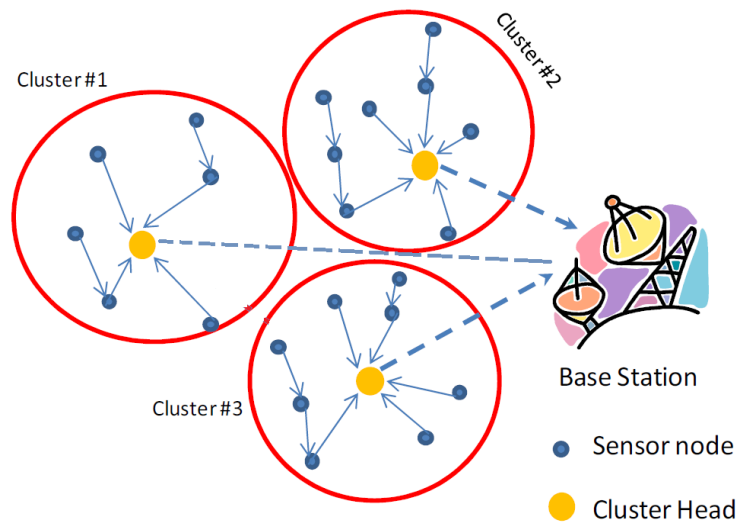

Figure 2.2: A simple cluster scheme

A simple radio model is assumed in LEACH protocol which describe the energy dissipation through the power amplifier, transmitter, electronic devices and the receiver. The radio model used to study LEACH and its other variants is shown in fig.2.3.

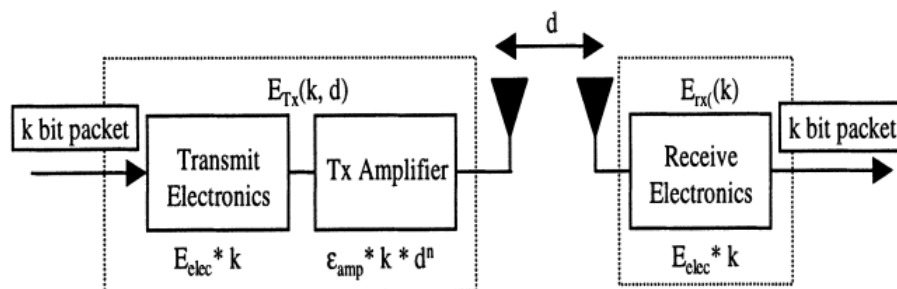

Figure 2.3: Radio energy dissipation model

LEACH-Centralized (LEACH-C)[3] is similar to LEACH protocol in the perspective of that it also has the cluster head and cluster formation concept which is designed to improve the performance of LEACH. But in LEACH-C nodes don't select themselves as CH instead sink is the entity that makes the decision of which nodes will become cluster-heads. It assumes that each node sends information about its current location (possibly determined using GPS) and residual energy level to the sink. In this way sink gathers location from the nodes and then broadcasts the decision to cluster heads. But problem with LEACH-C is that it is very much affected by the location of the sink and once the energy cost of communicating with the base station becomes higher than the energy cost

for cluster formation, LEACH-C does not provide good performance. Also LEACH-C does not fit for large area networks.

Chapter 3

Proposed Algorithm

*Energy Model and Basic
Assumptions*

Proposed Scheme

Chapter 3

Proposed Algorithm

3.1 Energy Model and Basic Assumptions

We consider a wireless sensor network consisting of N sensors uniformly distributed. Basic assumptions that are made for underlying network scenario and the sensor nodes are:

1. The base station is located far from sensor environment. Sensor nodes and base station are all stationary after installation.
2. Periodically the recently sensed data and information by all nodes are gathered and sent to the data sink after aggregation.
3. Nodes are identical with respect to energy and processing abilities. Each sensor node is having a unique identifier (ID).
4. Sensor nodes are capable of controlling their power level to adjust the amount of transmission power according to the distance to the intended recipient.
5. A node can find the distance to another node based on the received signal strength if the power of transmitting node is known.

3.2 Proposed Scheme

The cluster head receives the data from its members and aggregates them before sending this huge data to the base station. All these activities deplete the nodes' energy level very fast. So another s-node is being planned to be selected to do the job of transmission to the base station. An attempt has been also made to use the nodes' ability to change

their transmission power levels so that they can communicate to their intended recipient in efficient way with that transmission power only [10].

The energy coefficients and parameters that are used for radio energy dissipation model used by LEACH protocol is given as:

Transmission energy to send l-bit of data over distance d is :

$$E_{tx} = \begin{cases} lE_{elec} + lE_{fs}d^2, & \text{if } d \leq \delta; \\ lE_{elec} + lE_{mp}d^4, & \text{if } d > \delta \end{cases}$$

Energy spent to receive data is defined as:

$$E_{Rx} = lE_{elec}$$

where

l :packet size in bits

E_{elec} =Energy to send 1 bit data (50nJ)

E_{fs} =Energy coefficient for free space(10pJ)

E_{mp} =Energy coefficient for multipath(0.0013pJ)

$$\delta = \sqrt{E_{fs}/E_{mp}}$$

Energy dissipation for all the three types of sensor nodes is given as:

for Cluster Heads

$$E_{tx} = \begin{cases} l(E_{DA} + E_{elec}) + lE_{fs}d^2, & \text{if } d \leq \delta; \\ l(E_{DA} + E_{elec}) + lE_{mp}d^4, & \text{if } d > \delta \end{cases}$$

and

$$E_{Rx} = lE_{elec}$$

for Normal Sensor Nodes

$$E_{tx} = \begin{cases} lE_{elec} + lE_{fs}d^2, & \text{if } d \leq \delta; \\ lE_{elec} + lE_{mp}d^4, & \text{if } d > \delta \end{cases}$$

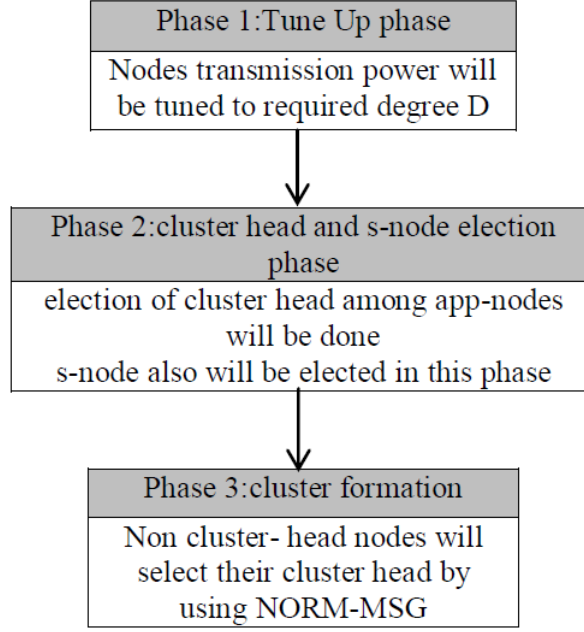

Figure 3.1: Tune-up phase, Cluster head and s-node election phase, cluster formation phase

for S-Nodes

$$E_{tx} = \begin{cases} lE_{elec} + lE_{fs}d^2, & \text{if } d \leq \delta; \\ lE_{elec} + lE_{mp}d^4, & \text{if } d > \delta \end{cases}$$

and

$$E_{Rx} = lE_{elec}$$

where E_{DA} = Data Aggregation Energy(5nJ/bit)

LEACH defines a parameter k_{optm} (optimal number of CHs) but a different parameter k_{ini} is taken in our scheme which is greater than k_{optm} to obtain well distributed CHs. The k_{ini} is set to have value greater than k_{optm} because we want that only high energy nodes cover the whole network area and this value is taken as double of k_{optm} . Every node will calculate a threshold value T_n described in equation 2.1 and will generate a random number between 0 and 1 and if this value is less than the threshold value then the node will elect itself as 'appropriate candidate node'(app-node) for becoming cluster head. All the required steps of every round are shown in the Fig.3.1.

In the proposed algorithm in the beginning of every round these app-nodes will employ tune up phase which is described below:

3.2.1 Tune-up Phase

Controlling of the nodes' transmission power levels may result in the loss of network connectivity. So for becoming sure about the network connectivity throughout its life time we have used the result that is proposed by Xue and Kumar in [11]. They proved that the result given in [12] is not valid for large networks. They state that a large network of 'n' nodes will be asymptotically connected if each node connects to at least $5.1774 \log n$ closest neighbors. So we define a degree threshold (D) as $D = 5.1774 \log n$ that will preserve network connectivity.

So for the app-nodes to set their transmission power level to required degree D the proposed method is:

- app-node will send a message 'update-msg'.
- The receiving nodes will send the acknowledgement for the 'update-msg'.
- The app-node will count all these acknowledgements.
- Now if acknowledgements are equal to required degree D then set this transmission power level as base power level.
- Otherwise if acknowledgements are less than D then app-node will increase its transmission power level until the required degree D is achieved and will set this transmission power level as its base power level.
- Otherwise if acknowledgements are greater than D then app-node will decrease its transmission power level until the required degree D is achieved and will set this transmission power level as its base power level.

In this way these app-nodes will be tuned up to the required degree D as intended.

3.2.2 Cluster-head and s-node election phase

The proposed method for election of cluster head and s-node is:

- The app-node will broadcast the contention message 'contention-msg', which consists of their residual energy, at their set transmission power.

- Each candidate will compare its residual energy with other app nodes.
- If candidate's energy level is highest then it will elect itself as cluster head.
- Then the candidate with the second highest residual energy will elect itself as s-node (if there is no other app-node then at the time of cluster formation highest residual energy node except cluster head will become s-node).
- The remaining nodes with lower residual energy will back-off and they will act as normal nodes.

While election of cluster head the candidate with second highest residual energy will save the node id of highest residual energy node because it is going to become the cluster head for its cluster. After that the s-node will send a message 's-node-msg' to this cluster head and after receiving this message cluster head will acknowledge that message. In this way s-nodes for every cluster will be chosen. The cluster head will gather the sensed data from normal nodes of its cluster and after aggregation this cluster head will send aggregated data to its cluster's s-node. Then the s-node will send this data to the sink. In this way most energy consuming communication task is distributed throughout the network by cluster head nodes and s-nodes.

3.2.3 Cluster Formation

In the last step, non-cluster head nodes will be assigned to CHs for cluster formation. After electing CHs they send CLHD-MSG. Normal nodes will acknowledge a CLHD-MSG message by 'NORM-MSG' containing its ID, to the CHs. Normal nodes may receive more than one CLHD-MSG and they will acknowledge the message that will have higher signal strength. In this way cluster formation takes place.

Fig.3.2 shows the flow of all the steps.

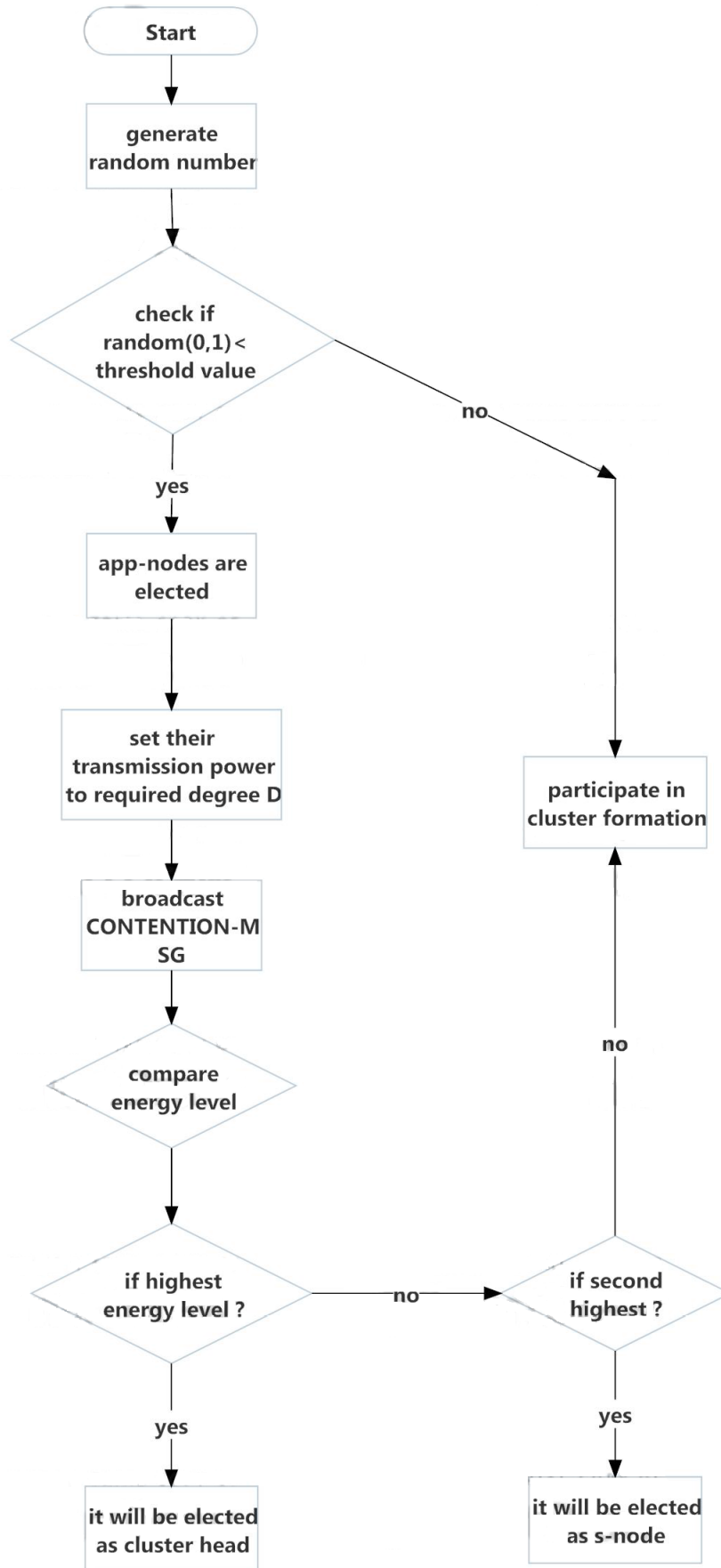

Figure 3.2: Flow Chart of Proposed Scheme

Chapter 4

Simulation and Analysis

Simulation Environment

Simulation Analysis

Chapter 4

Simulation and Analysis

This chapter gives overview about simulation and its analysis. Section 4.1 explains about simulation environment and Section 4.2 explains about implementation analysis.

4.1 Simulation Environment

In this part, we evaluate the performance of the proposed scheme and compare its performance with LEACH protocol, using the same energy model used in leach protocol with same initial values and same scenario. The experiments are done with diverse number of nodes placed in a $100m * 100m$ field. Each sensor node is assumed to have an initial energy of 0.5joules . The general simulation parameters are shown in table 4.1.

Table 4.1: Simulation Parameters

Parameter	Value
simulation area	100*100
initial energy	0.5 <i>J</i>
sink	50 * 125 <i>m</i> and 50 * 175 <i>m</i>
transmission electronics	50 <i>nJ/bit</i>
nodes	100 and 300
ϵ_{fs}	10 <i>pJ/bit/m²</i>
ϵ_{mp}	0.0013 <i>pJ/bit/m⁴</i>
Data size	500 <i>bytes</i>
E_{DA}	5 <i>nJ/bit/signal</i>
equal energy(start up)	yes

4.2 Simulation Analysis

Network lifetime is defined until the first node dies. The results of network lifetime are described in Fig.4.1 and Fig.4.2. It is concluded that the proposed algorithm improves lifetime of nodes. With our approach first node remain alive in the network longer than LEACH and LEACH-C for both the cases. This is because in LEACH, for becoming CH all nodes have same chances. With proposed approach first node dies around 1050 round for first case (n=100) while for leach it dies around 850 round. For second case (n=300) also with proposed algorithm first node dies around 1010 while for leach it dies around 830. Fig.4.3 and Fig.4.4 shows the average total energy dissipation of all nodes in network which shows that with proposed scheme nodes sustain energy for longer time than LEACH in both the cases.

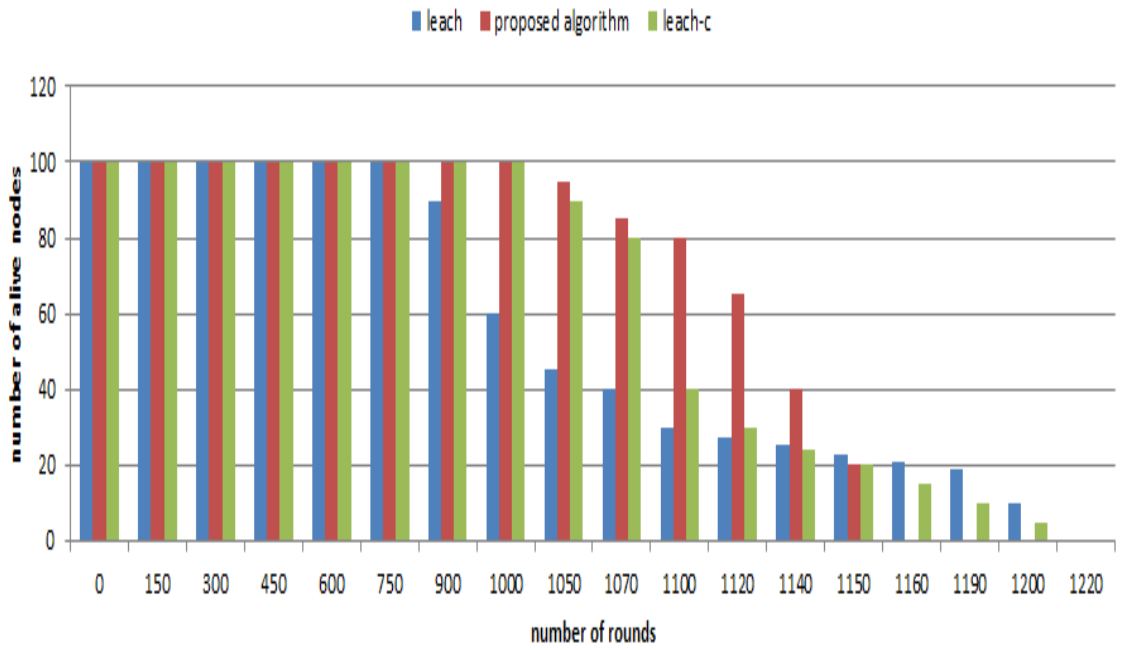

Figure 4.1: Number of alive nodes (100 nodes)

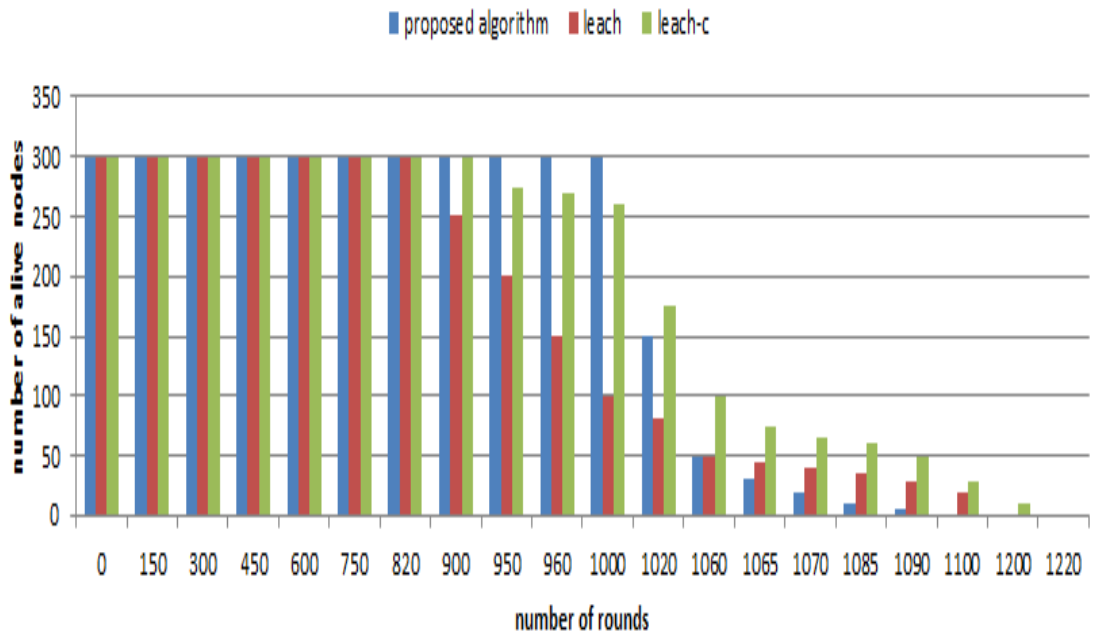

Figure 4.2: Number of alive nodes (300 nodes)

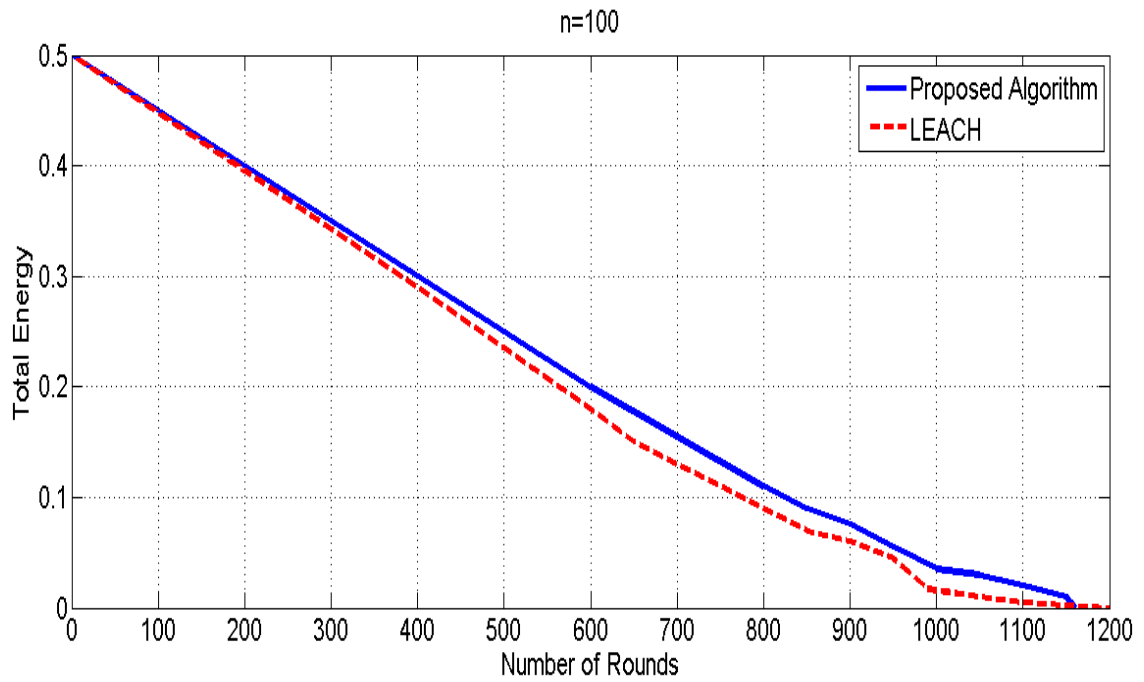

Figure 4.3: Energy dissipation for 100 nodes

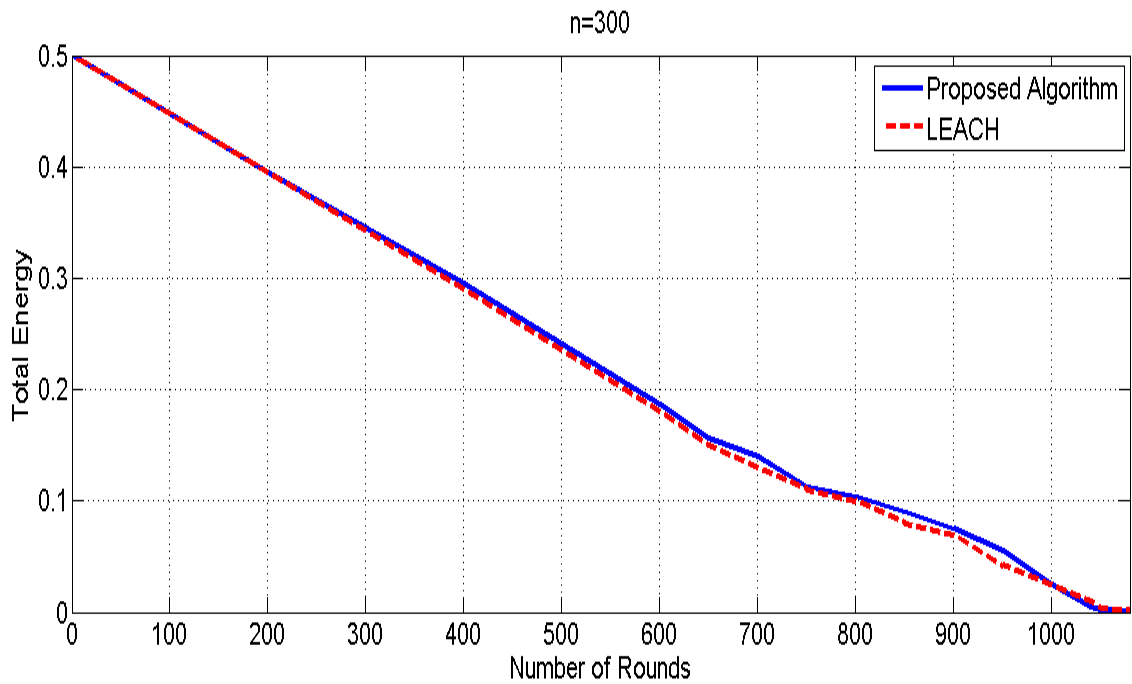

Figure 4.4: Energy dissipation for 300 nodes

Chapter 5

Conclusion and Future Work

Chapter 5

Conclusion and Future Work

In this thesis, a new methodology for improvement of clustering algorithm of WSN is introduced. We use the capability of the nodes of changing their transmission power levels and also introduce the notion of special nodes (s-node) for sending the aggregated data of cluster heads to the sink. Thus these improvements show that the proposed method is having longer life time for wireless sensor networks than LEACH and LEACH-C protocols. Detailed simulations of wireless sensor network environment demonstrate that our approach is a good candidate and has the ability of extending the life time of the whole network.

Bibliography

- [1] Akyildiz, Ian F., et al. "Wireless sensor networks: a survey." *Computer networks* 38.4 (2002): 393-422.
- [2] Heinzelman, Wendi B., Anantha P. Chandrakasan, and Hari Balakrishnan. "An application-specific protocol architecture for wireless microsensor networks." *Wireless Communications, IEEE Transactions on* 1.4 (2002): 660-670.
- [3] Heinzelman, Wendi Beth. *Application-specific protocol architectures for wireless networks*. Diss. Massachusetts Institute of Technology, 2000.
- [4] Abbasi, Ameer Ahmed, and Mohamed Younis. "A survey on clustering algorithms for wireless sensor networks." *Computer communications* 30.14 (2007): 2826-2841.
- [5] Pantazis, Nikolaos A., Stefanos A. Nikolidakis, and Dimitrios D. Vergados. "Energy-efficient routing protocols in wireless sensor networks: A survey." *Communications Surveys Tutorials, IEEE* 15.2 (2013): 551-591.
- [6] Kong, Hyung Yun. "Energy efficient cooperative LEACH protocol for wireless sensor networks." *Communications and Networks, Journal of* 12.4 (2010): 358-365.
- [7] Beydoun, Kamal, and Violeta Felea. "Energy-efficient WSN infrastructure." *Collaborative Technologies and Systems, 2008. CTS 2008. International Symposium on*. IEEE, 2008.
- [8] Chinara, Suchismita, and Santanu Kumar Rath. "Energy efficient mobility adaptive distributed clustering algorithm for mobile ad hoc network." *Advanced Computing and Communications, 2008. ADCOM 2008. 16th International Conference on*. IEEE, 2008.

- [9] Dargie, Walteneus, and Christian Poellabauer. *Fundamentals of wireless sensor networks: theory and practice*. John Wiley Sons, 2010.
- [10] Gupta, Piyush, and Panganmala R. Kumar. "The capacity of wireless networks." *Information Theory, IEEE Transactions on* 46.2 (2000): 388-404.
- [11] Xue, Feng, and Panganamala R. Kumar. "The number of neighbors needed for connectivity of wireless networks." *Wireless networks* 10.2 (2004): 169-181.
- [12] Kleinrock, Leonard, and John Silvester. "Optimum transmission radii for packet radio networks or why six is a magic number." *Proceedings of the IEEE National Telecommunications Conference*. Vol. 4. Birimingham, Alabama, 1978.
- [13] Aslam, M., et al. "Survey of extended LEACH-Based clustering routing protocols for wireless sensor networks." *High Performance Computing and Communication 2012 IEEE 9th International Conference on Embedded Software and Systems (HPCC-ICISS), 2012 IEEE 14th International Conference on*. IEEE, 2012.
- [14] Boyinbode, Olutayo, Hanh Le, and Makoto Takizawa. "A survey on clustering algorithms for wireless sensor networks." *International Journal of Space-Based and Situated Computing* 1.2 (2011): 130-136.
- [15] Javaid, N., Rahim, A., Nazir, U., Bibi, A., Khan, Z. A. (2012, June). Survey of extended LEACH-Based clustering routing protocols for wireless sensor networks. In *High Performance Computing and Communication 2012 IEEE 9th International Conference on Embedded Software and Systems (HPCC-ICISS), 2012 IEEE 14th International Conference on* (pp. 1232-1238). IEEE.
- [16] Kim, Do-Seong, and Yeong-Jee Chung. "Self-organization routing protocol supporting mobile nodes for wireless sensor network." *Computer and Computational Sciences, 2006. IMSCCS'06. First International Multi-Symposiums on*. Vol. 2. IEEE, 2006.

- [17] Mhatre, Vivek, and Catherine Rosenberg. "Homogeneous vs heterogeneous clustered sensor networks: a comparative study." *Communications, 2004 IEEE International Conference on*. Vol. 6. IEEE, 2004.
- [18] Fedor, Szymon, and Martin Collier. "On the problem of energy efficiency of multi-hop vs one-hop routing in Wireless Sensor Networks." *Advanced Information Networking and Applications Workshops, 2007, AINAW'07. 21st International Conference on*. Vol. 2. IEEE, 2007.